

GLOBE VALVES

Installation Instructions

Extracting Valve Ring

1. Remove Bonnet (11) and Stem Assembly (6) by opening valve to wide open position and removing Bonnet Nut (11) and working assembly free of body.
2. Insert Pulling Tool into ring pocket making sure that puller housing is located evenly on neck of valve body. Slotted cap 'A' should rest on Lantern (8) as shown in Fig. 1. Rotate until pin 'B' can be pressed into slot and hold while knurled nut 'C' counter clockwise until refusal.
3. With an adjustable wrench, turn hex nut 'D' in a clockwise direction until internal parts are fully extracted, as shown in Fig. 2.
4. Spin hex nut all the way back on so that withdrawn parts can be fully extended from puller housing, then turn knurled nut 'C' clockwise which will release parts from puller.

To Insert New Valve Ring

1. Place Valve Ring (3), including O-ring, on Ring Seater tool as shown in Fig. 3 and drive into valve body as far as it will go keeping Ring Seater as straight as possible.
2. Drop Lantern (8) into body with large I.D. and wider band facing up making sure Lantern (8) sits evenly on ring.
3. Before installing Bonnet Assembly (10) into body, fully retract stem making sure spring is located between back of Piston (4) and Bonnet (10). Install into body. Tighten down Bonnet Nut (11) until refusal.

Note: When installing new spring, Split Nut (5), Piston (4) must be disassembled from Stem (6). Install new spring over stem against Bonnet (10). Reassemble Split Nut (5) and Piston (4). Hold spring against Bonnet (10).

Precautions: Make sure ring pocket is free of scale, rust or other obstruction before replacing valve ring. Make sure parts are replaced in same order as removed.

Base ring no longer necessary (older valves only).



Spring to be installed in
back of piston
Large I.D. facing up



ASSEMBLED AND/OR MADE IN THE USA



ISO 9001
ONE-STEP Global

PARTS FOR BRONZE UNIT		
ITEM NO.	PART	PRODUCT CODE
1	BODY GLOBE SCREWED ENDS	GVBDFCPS
1	BODY GLOBE UNION TYPE	GVEBDFB
3	VALVE RING WITH O-RING Elas./PTFE	GVRING
4	PISTON (includes Item 5) 316 SST	GVPISTSPITASSY
5	SPLIT NUT (LEFT HAND THREAD) 316 SST	GVSPPLITNUT
6	STEM (includes Item 7) 416 SST	MUSTEMKIT
7	STEM STOP (set of 6) 304 SST	GVSSSTP
8	LANTERN Brass	GVLANTR
9	SPRING (set of 6) 302 SST	SPRG8027S
10	BONNET ASSEMBLY Bronze	GVBNB
11	BONNET NUT Brass	GVBNNUB
12	RETAINING RING (set of 6) 302 SST	GVRRNG
13	PACKING RING (3 pc. Virgin PTFE)	GVPACKCHEV
14	PACKING GLAND	GVGLBR
15	PACKING NUT Brass	GVPNUTBR
16	BLACK HAND WHEEL Cast Iron	GVHWFBLACK
16	RED HAND WHEEL Cast Iron	GVHWFRR
17	HAND WHEEL NUT (set of 6) 303 SST	GVLNUTSS
20	UNION GASKET (set of 6) Virgin PTFE	GVGA
21	UNION TAIL PIECE Brass	GVUTAILBR
22	INLET UNION NUT Brass	GVUNUTBR
23	ANGLE RECESSED GASKET Garlock	RECGA

PARTS FOR STAINLESS STEEL UNIT		
1	BODY GLOBE UNION TYPE 316 SST	GVBDFFS
1	BODY GLOBE ANGLE TYPE 316 SST	AVBDFSS
8	LANTERN 304 SST	GVLANSS
10	BONNET ASSEMBLY 303 SST	GVBNSS
11	BONNET NUT 303 SST	GVBNNUSS
14	PACKING GLAND 303 SST	GVGLSS
15	PACKING NUT 303 SST	GVPNUTSS
16	BLUE HAND WHEEL Cast Iron	GVHWFBLUE
16	ORANGE HAND WHEEL Cast Iron	GVHWFOR
20	UNION GASKET SPIRAL WOUND (set of 6) SST	GASW015001000063MA
21	UNION TAIL PIECE 303 SST	GVUTAILSS
22	INLET UNION NUT 303 SST	GVUNUTSS
24	GLOBE VALVE GASKET Bonn/Body SST	GVBNGA

OPTIONAL TOOLS		
-	VALVE PULLER	GVPULLER
-	VALVE SEATER	GVSEATER

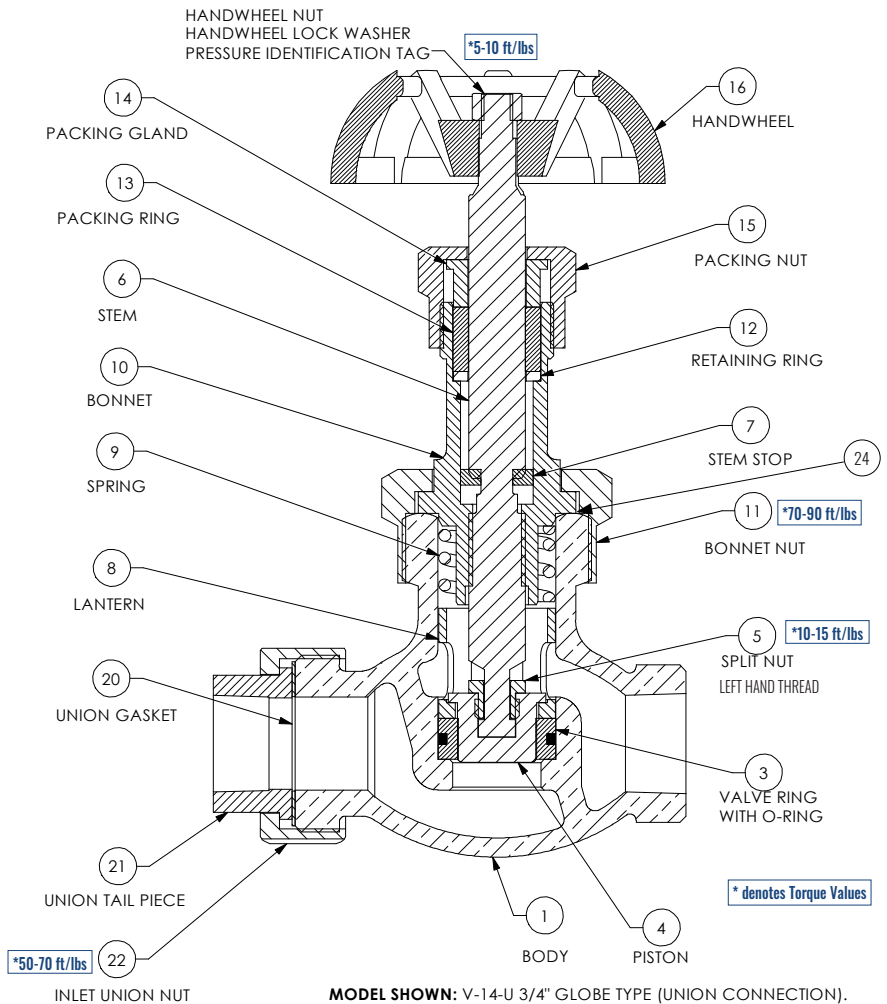

MODEL SHOWN: V-14-U 3/4" GLOBE TYPE (UNION CONNECTION).
MODELS AVAILABLE: V-14-S 3/4" GLOBE TYPE (SCREWED ENDS).
 V-18 3/4" ANGLE TYPE (SCREWED ENDS).
SST MODELS: V-65-SU, V-65-SS AND V-18-SS

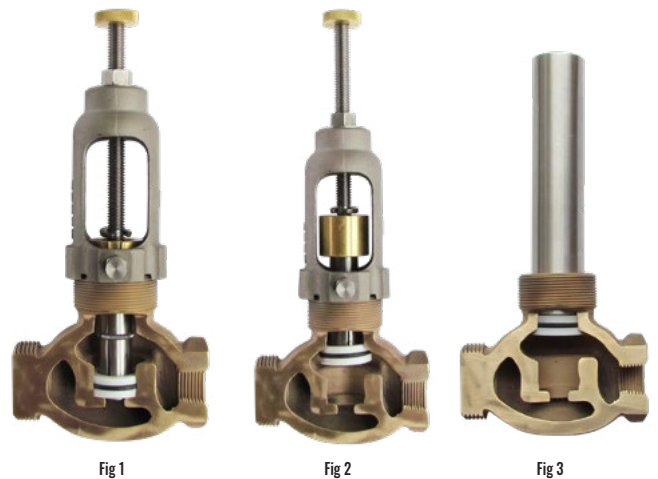

**STRAHMAN
GROUP**

PRECISION AND PERFORMANCE

STRAHMANGROUP.COM

WORLD HEADQUARTERS

2801 BAGLYOS CIRCLE, BETHLEHEM, PA 18020

P: +1 484.893.5080 F: +1 484.893.5099

E: STRAHMAN@STRAHMAN.COM

FRANCE | GERMANY | HONG KONG | CHINA