



BUTTERFLY VALVES

CAST IRON ACTUATED AND MANUAL



BUTTERFLY VALVES

BY SERIES

FEATURES AND BENEFITS

ISO MOUNTING PAD

The true ISO pad allows for direct mounting of a variety of gears, pneumatic and electric actuators, and a 10 position manual handle.

BUSHING

The stem bushing helps to reduce torque and isolate stem from valve body.

SHAFT SEAL

An EPDM O-ring creates a bubble tight design while limiting contact areas between the body and shaft.

DISC

A 316 SS disc is standard on all BY and MY series models. Aluminum bronze and cast iron discs also are available upon request.

BODY

The cast iron body is epoxy coated for a durable, attractive finish. A fully encapsulated body gives total protection, with the body never coming into contact with the fluid.

SHAFT

A square shaft allows for mounting to true ISO mount pneumatic and electric actuators as well as gear operators.

ANTI-BLOWOUT DESIGN

The standard shaft is 316 SS and never comes into contact with the media. The one piece design ensures positive disc positioning.

EXTENDED NECK

The elongated neck shaft creates added heat resistance.

SEAT LINER

EPDM, BUNA-N, Viton®, and PTFE liners are available. The seat face guarantees a perfect seal with the flanges without additional joints or gaskets.

BOLTING

Standard flange locating holes allow for quick installation and correct alignment. The standard valve is designed to ANSI standards.

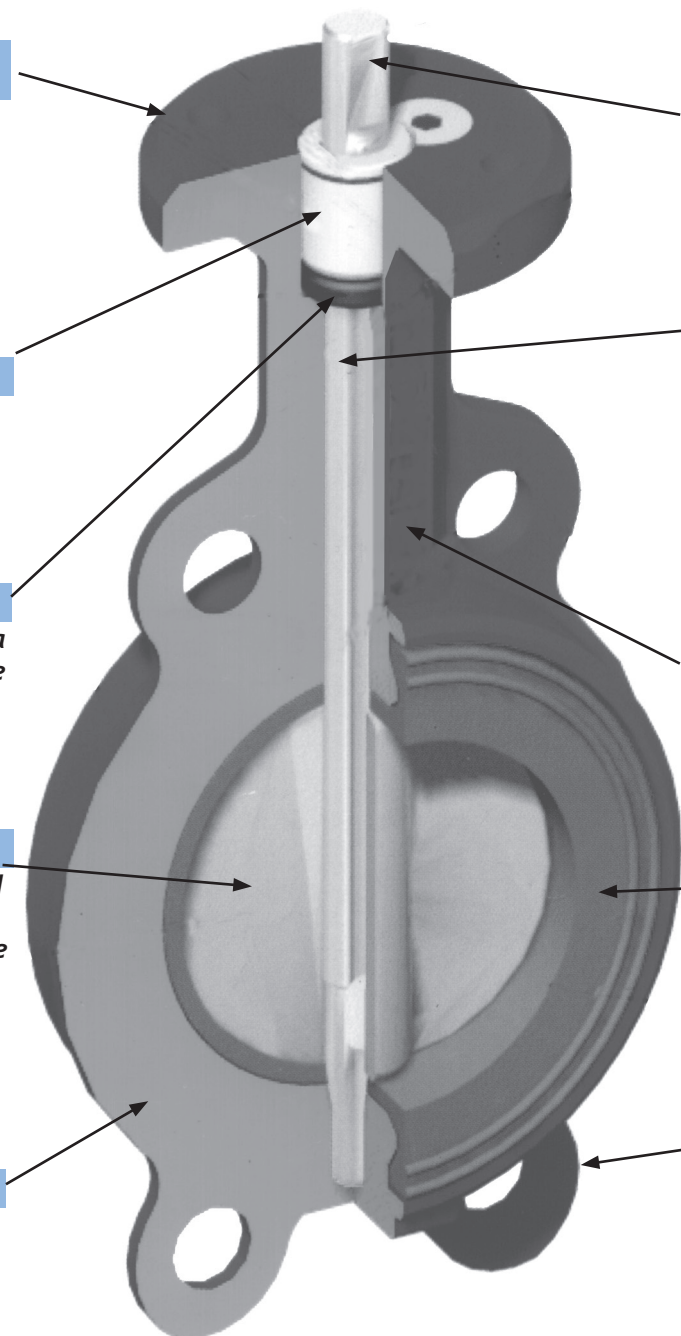

BUTTERFLY VALVES

BY SERIES



LUG STYLE

10 throttling positions are available with each standard handle on manually operated valves. The ergonomic design allows for easy operation on all sizes. A padlocking device is optional with all lever handles.



WAFER STYLE

BUTTERFLY VALVES

BY SERIES



Lug style with pneumatic actuator and accessories

AUTOMATED CAST IRON

- Wafer and lug style cast iron BFVS - 2" through 12"
- SS stem and disc as standard
- EPDM, BUNA-N, VITON® or PTFE® seats
- Direct mount for low profile, cost-efficient operation
- Pneumatic, electric and gear operators

PNEUMATIC ACTUATORS

DOUBLE ACTING

	A	B	C	D	E	F	G	ACTUATOR
2"	10.30	3.17	1.69	6.38	13.45	1.77		PN-63DA
2-1/2"	10.85	3.17	1.81	6.38	14.35	1.77		PN-63DA
3"	11.09	3.17	1.81	6.38	14.83	1.77		PN-63DA
4"	12.46	3.17	2.05	6.38	16.95	1.77		PN-63DA
5"	14.08	4.17	2.20	9.35	19.08	2.30		PN-85DA
6"	15.10	4.85	2.69	10.69	20.57	2.30		PN-100DA
8"	17.62	5.39	2.87	12.91	24.51	2.68		PN-115DA
10"	20.49	6.45	3.44	16.85	28.48	3.15		PN-145DA
12"	22.89	7.35	3.07	16.93	32.42	3.94		PN-161DA

SPRING RETURN

	A	B	C	D	E	F	G	ACTUATOR
2"	10.95	3.72	1.69	8.15	14.10	2.07		PN-75SR
2-1/2"	11.50	3.72	1.81	8.15	15.00	2.07		PN-75SR
3"	12.19	4.17	1.81	9.35	15.93	2.30		PN-85SR
4"	14.07	4.85	2.05	10.69	18.56	2.68		PN-100SR
5"	14.59	4.85	2.20	10.69	19.59	2.68		PN-100SR
6"	17.64	6.45	2.20	16.85	23.11	3.44		PN-145SR
8"	19.61	7.35	2.36	16.93	26.50	3.94		PN-161SR
10"	23.17	8.82	2.68	20.94	31.16	4.41		PN-201SR
12"	29.79	10.48	3.07	26.06	39.32	5.24		PN-241SR*

*INCLUDES CARBON STEEL MOUNTING KIT

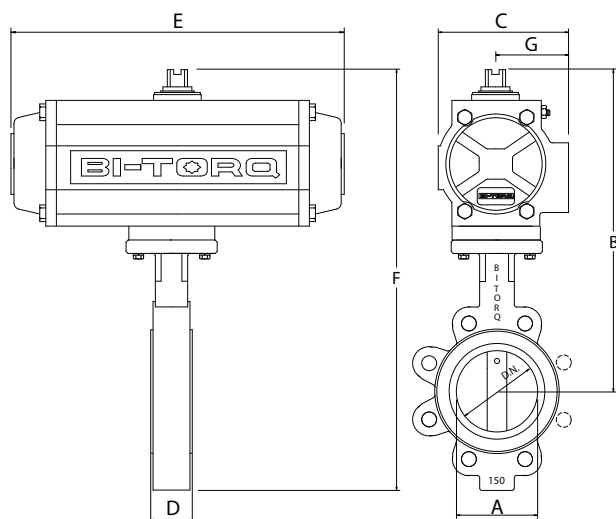

ALL STANDARD PNEUMATIC ACTUATORS SIZED FOR 80 PSI SUPPLY; PLEASE CONSULT OUR SALES STAFF FOR OTHER COMBINATIONS.

ELECTRIC ACTUATORS

	A	B	C	D	E	F	ACTUATOR
2"	12.22	4.25	1.69	6.88	15.37		BI-200-A-4-P1
2-1/2"	12.77	4.25	1.81	6.88	16.27		BI-200-A-4-P1
3"	13.01	4.25	1.81	6.88	16.75		BI-300-A-4-P1
4"	16.50	7.00	2.05	7.00	20.99		BI-675-A-4-P1
5"	17.02	7.00	2.20	7.00	22.02		BI-1000-A-4-P1*
6"	17.53	7.00	2.20	7.00	23.00		BI-1500-A-4-P1*
8"	22.50	10.00	2.36	10.00	29.39		BI-3800-A-4-P1*
10"	27.13	10.00	2.68	10.00	35.12		BI-3800-A-4-P1**
12"	28.91	11.42	3.07	17.60	38.44		BI-5310-A-4***

ALL ELECTRIC ACTUATOR DIMENSIONS ARE FOR NEMA 4 ENCLOSURES. FOR NEMA 7 ENCLOSURE DIMENSIONS, PLEASE CONSULT OUR SALES STAFF.

*INCLUDES DECLUTCHABLE MANUAL OVERRIDE
 **INCLUDES DECLUTCHABLE MANUAL OVERRIDE AND MOUNTING KIT
 *** INCLUDES MANUAL OVERRIDE AND MOUNTING KIT. THIS MODEL IS OUR BH SERIES - SEE SALES FOR LOOK OF ACTUATOR.

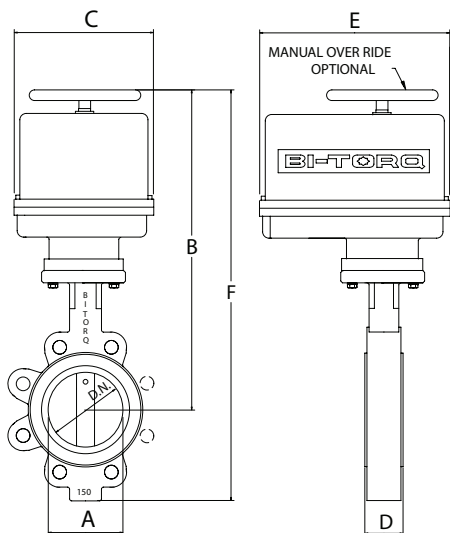

DIMENSIONS AND MATERIALS

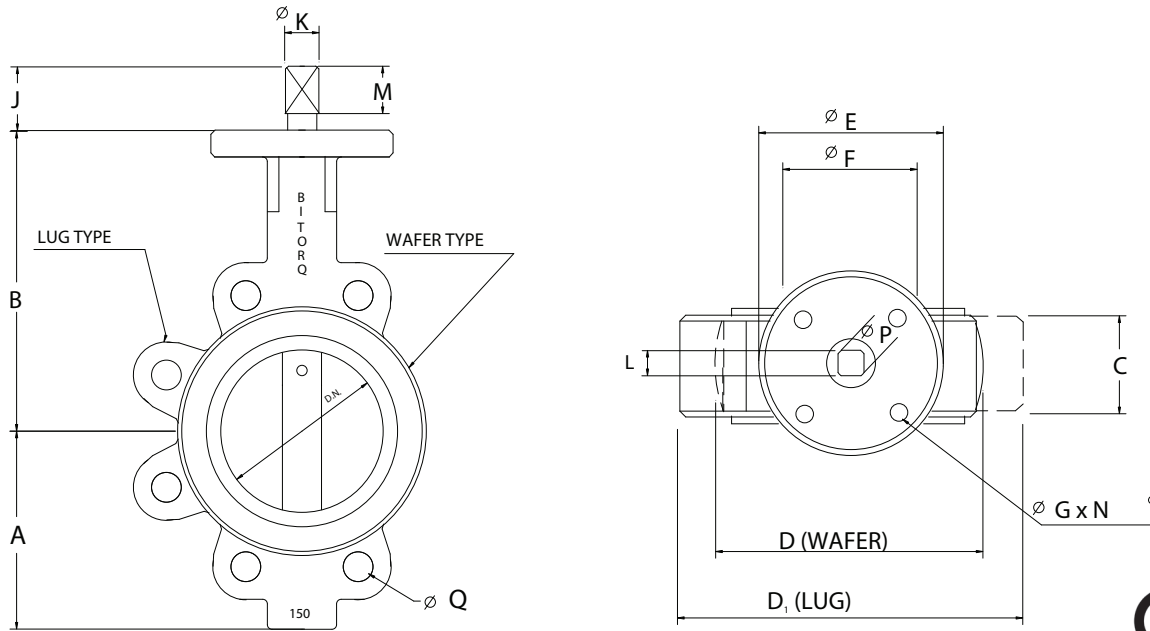

THE BY SERIES IS DESIGNED TO FIT BETWEEN ANSI CLASS 125# AND 150# FLANGES



DIMENSIONS

SIZE	ISO	A	B	C	D (WAFFER)	D (LUG)	EØ	FØ	G x No.	J	KØ	L	M	Q (LUG ONLY)	WEIGHT (LBS.) LUG	WEIGHT (LBS.) WAFFER
2"	F07	3.15	6.34	1.69	4.02	5.98	3.54	2.76	0.354 x 4	1.023	0.551	0.433	0.669	4 x 5/8-11	8.4	5.5
2-1/2"	F07	3.50	6.89	1.81	4.76	6.74	3.54	2.76	0.354 x 4	1.023	0.551	0.433	0.669	4 x 5/8-11	9.2	7.0
3"	F07	3.74	7.13	1.81	5.47	7.87	3.54	2.76	0.354 x 4	1.023	0.551	0.433	0.669	4 x 5/8-11	10.3	7.9
4"	F07	4.49	7.87	2.05	6.30	9.02	3.54	2.76	0.354 x 4	1.181	0.709	0.551	0.826	8 x 5/8-11	15.8	10.8
5"	F07	5.00	8.39	2.20	7.48	10.00	3.54	2.76	0.354 x 4	1.181	0.709	0.551	0.826	8 x 3/4-10	21	15.4
6"	F07	5.47	8.90	2.20	8.46	11.02	3.54	2.76	0.354 x 4	1.299	0.866	0.669	0.945	8 x 3/4-10	23	17.2
8"	F07	6.89	10.24	2.36	10.59	13.50	3.54	2.76	0.472 x 4	1.299	0.866	0.669	0.945	8 x 3/4-10	40	29
10"	F10	7.99	11.50	2.68	13.11	15.98	4.92	4.02	0.472 x 4	1.850	1.102	0.866	0.945	12 x 7/8-9	59	42.2
12"	F10	9.53	13.27	3.07	15.08	19.02	4.92	4.02	0.472 x 4	1.850	1.102	0.866	0.945	12 x 7/8-9	88	71.5

OPTIONAL BUTTERFLY VALVES AVAILABLE THROUGH 24". HIGH PERFORMANCE, ALL STAINLESS AND SANITARY VALVES ALSO AVAILABLE.

10 POSITION HANDLE

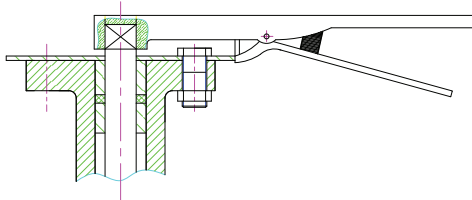

WITH 10 POSITION PLATE

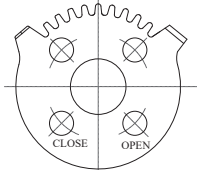

ALL MANUAL VALVES INCLUDE A 10-POSITION HANDLE.
CAST IRON GEAR OPERATORS ARE ALSO AVAILABLE.

BILL OF MATERIALS

DESCRIPTION	QTY	MATERIAL
BODY	1	CAST IRON
BOTTOM BUSHING	1	BRONZE
SHAFT	1	316 SS
SEAT	1	EPDM, BUNA, VITON, PTFE
DISC	1	316 SS
TAPER PINS	1-2	316 SS
NAME PLATE	1	316 SS
RIVETS	2	316 SS
TOP BUSHING	1	BRONZE
O-RING	1	EPDM

SPECIFICATIONS

DESIGN AND STANDARDS:
MSS-SP67, API 609
FLANGE ENDS ANSI B16.1

WORKING PRESSURE:
225 PSI TO 8"
150 PSI 10"-12"

SHELL TEST:
350 PSI

SEAL TEST:
250 PSI

WORKING TEMPERATURE:
EPDM: -30° F TO +275° F
BUNA-N: +10° F TO +180° F
VITON®: 0° F TO 350° F
PTFE: -20° F TO +250° F

BUTTERFLY VALVES

BY SERIES

GEAR OPERATED

MY SERIES BFV WITH DN SERIES
CAST IRON GEAR OPERATOR

A	B	C	D	E	GEAR
2"	6.00	4.13	1.69	5.00	DN50
2-1/2"	6.00	4.13	1.81	5.00	DN65
3"	6.00	4.13	1.81	5.00	DN80
4"	6.00	4.13	2.05	5.00	DN100
5"	8.00	4.13	2.20	5.00	DN125
6"	8.00	4.13	2.20	5.00	DN150
8"	9.45	6.00	2.36	6.96	DN200
10"	9.45	6.00	2.68	6.96	DN250
12"	9.45	6.00	3.07	6.96	DN300

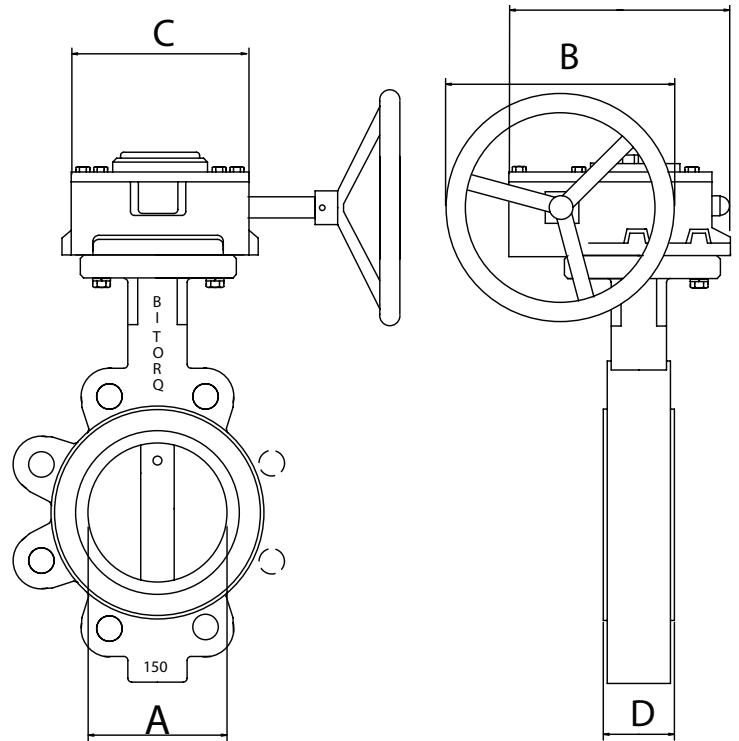

Lever Handle Butterfly Valves 2" Through 8"

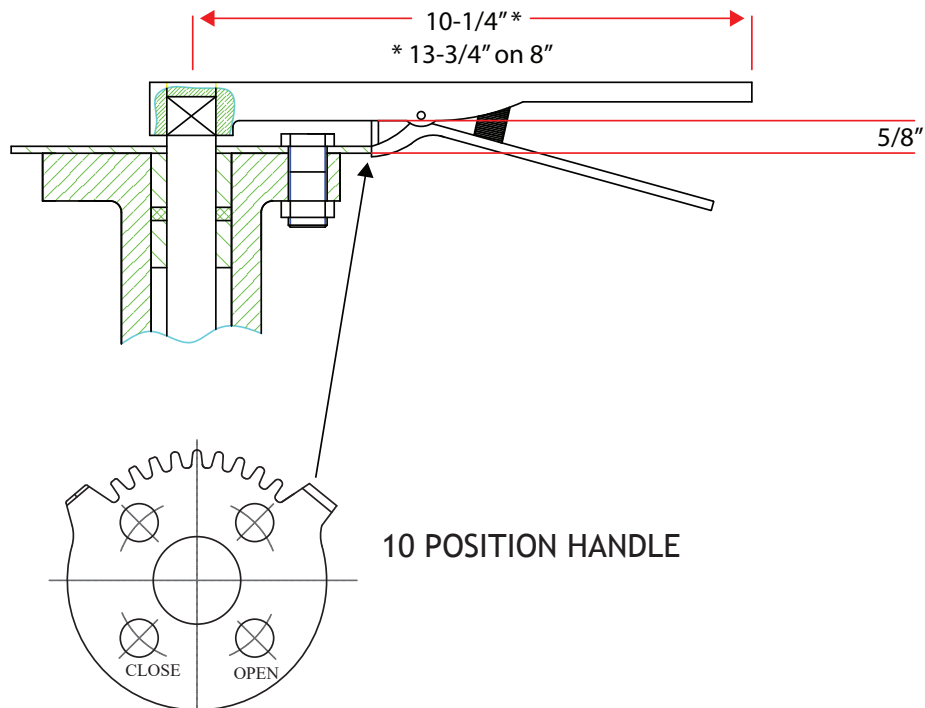

AUTOMATION ACCESSORIES

BI-TORQ VALVE AUTOMATION OFFERS A WIDE VARIETY OF ACCESSORIES FOR OUR AUTOMATED BUTTERFLY VALVE ASSEMBLIES. ALL ACCESSORY COMPONENTS ARE MOUNTED AND TESTED ON THE ACTUATOR BY OUR TRAINED FACTORY PERSONNEL.

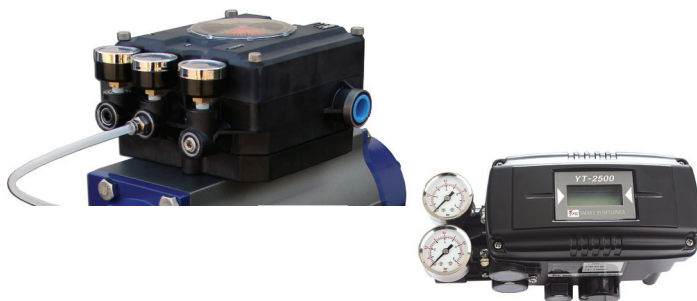

**ANALOG (3-15 PSI & 4-20MA)
AND SMART POSITIONERS**



**LIMIT SWITCH
POSITION INDICATORS**



**NAMUR MOUNT
SOLENOIDS**

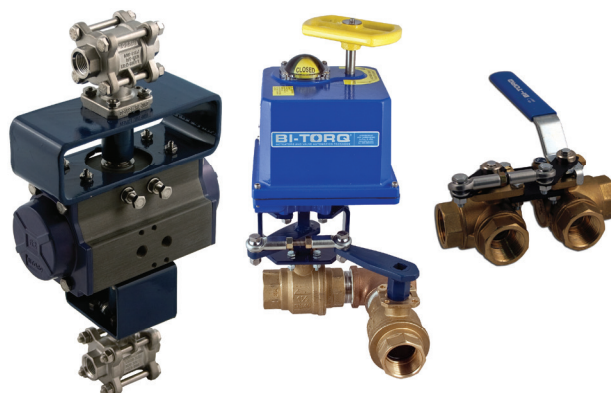

**CUSTOMIZED
ASSEMBLIES**

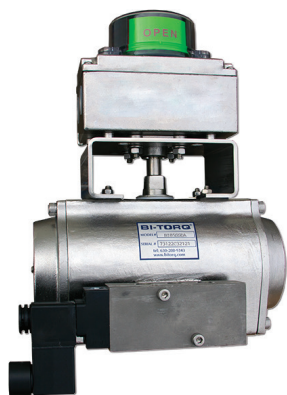

**STAINLESS STEEL
VERSIONS TOO!**

**LOCK-OUT
KITS**



THE STRAHMAN FAMILY OF PRODUCTS INCLUDE:



WASH DOWN EQUIPMENT

Cleaning and sanitizing equipment for applications where safety is the number one concern — built to outlast and outperform all others.

AUTOMATED VALVES & THERMAL SHUT-OFF VALVES

Completely assembled automated valves and fire-safe thermal shut-off valves fabricated for quick and reliable problem-solving solutions for industrial applications.

PROCESS VALVES

Engineered solutions for the transfer of fluid and flow control for highly critical applications from sampling to inline process to permanent isolation.





© STRAHMAN GROUP | PUBLISHED 11.01.25

CONTACT US

Need more information? Give us a call today or visit our website.

 877-787-2462

 2801 Bagylos Circle
Bethlehem, PA 18020

 StrahmanGroup.com



PRECISION AND PERFORMANCE

an fch business