

# FS/FW SERIES 3-PC FIRESAFE BALL VALVES

## PNEUMATIC ACTUATORS

### PNEUMATIC FEATURES

- Rack and pinion design
- NAMUR accessory mounting on models 52 and higher
- Spring return and double acting
- Visual indicators
- Optional SS construction

ALL STANDARD ACTUATORS SIZED FOR 80 PSI AIR SUPPLY; PLEASE CONSULT FACTORY FOR OTHER COMBINATIONS

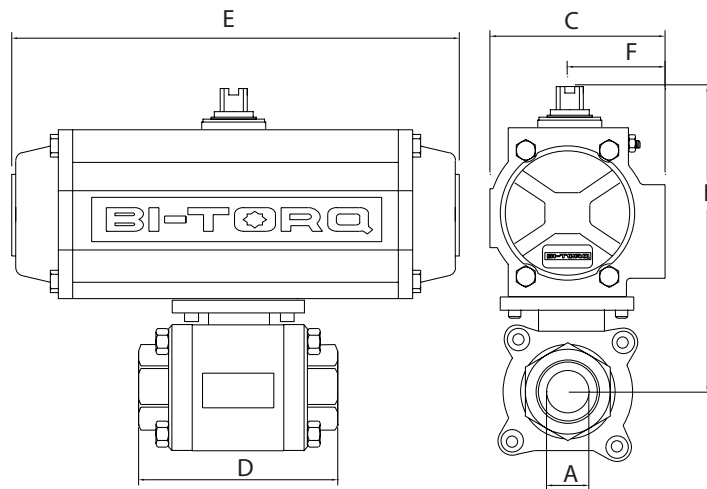

FOR A SELECTION OF AUTOMATION ACCESSORIES WE OFFER, REFER TO PAGE 31 OR VISIT STRAHMANGROUP.COM

DOUBLE ACTING ASSEMBLY DIMENSIONS							
A	B	C	D	E	F	ACT.	WT.
1/4"	7.21*	2.79	2.55	5.49	1.61	52DA	4.67
3/8"	7.21*	2.79	2.55	5.49	1.61	52DA	4.67
1/2"	7.21*	2.79	2.95	5.49	1.61	52DA	4.67
3/4"	5.29	2.79	3.14	5.49	1.61	52DA	5.08
1"	6.05	3.17	3.54	6.38	1.77	63DA	8.11
1-1/4"	6.2	3.17	4.33	6.38	1.77	63DA	10.62
1-1/2"	6.64	3.17	4.72	6.38	1.77	63DA	13.39
2"	7.64	3.72	5.51	8.15	2.07	75DA	21.61

\* MOUNTING KIT INCLUDED IN DIMENSIONS

SPRING RETURN ASSEMBLY DIMENSIONS							
A	B	C	D	E	F	ACT.	WT.
1/4"	7.65*	3.17	2.55	6.38	1.77	63SR	6.39
3/8"	7.65*	3.17	2.55	6.38	1.77	63SR	6.39
1/2"	7.65*	3.17	2.95	6.38	1.77	63SR	6.39
3/4"	5.73	3.17	3.14	6.38	1.77	63SR	7.52
1"	6.7	3.72	3.54	8.15	2.07	75SR	11.79
1-1/4"	7.3	4.17	4.33	9.35	2.30	85SR	16.73
1-1/2"	8.25	4.85	4.72	10.69	2.68	100SR	24.53
2"	9.78	5.39	5.51	12.91	2.87	115SR	40.02

\* MOUNTING KIT INCLUDED IN DIMENSIONS

## ELECTRIC ACTUATORS

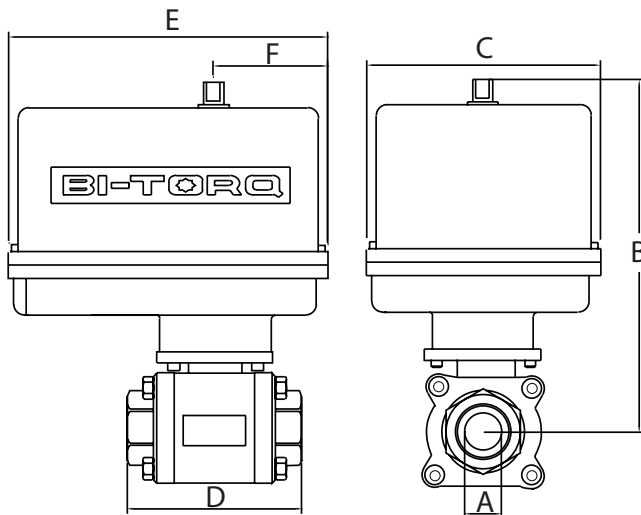

NEMA 4 ELECTRIC ASSEMBLY DIMENSIONS							
A	B	C	D	E	F	ACT.	WT.
1/4"	8.57**	4.00	2.55	5.63	2.31	100E	7.42
3/8"	8.57**	4.00	2.55	5.63	2.31	100E	7.42
1/2"	8.57**	4.00	2.95	5.63	2.31	100E	7.42
3/4"	7.65	4.25	3.14	6.88	2.43	200E	10.55
1"	7.97	4.25	3.54	6.88	2.43	200E	11.85
1-1/4"	8.12	4.25	4.33	6.88	2.43	300E	14.36
1-1/2"	8.56	4.25	4.72	6.88	2.43	300E	17.13
2"	11.03*	7.00	5.51	7.00	2.38	675E	29.10

\* DECLUTCHABLE MANUAL OVERRIDE INCLUDED IN DIMENSIONS

\*\* MOUNTING KIT INCLUDED IN DIMENSIONS

### ELECTRIC FEATURES

- 120VAC, 220VAC, 24VAC, 12VDC and 24VDC
- NEMA 4, 4X and 7 housings
- Manual overrides
- Visual indicators
- Open/close or modulating service

FOR NEMA 7 ELECTRIC DIMENSIONS OR OTHER CONFIGURATIONS, CONTACT OUR SALES STAFF.

FOR MORE INFORMATION ON BI-TORQ ACTUATORS, REFER TO OUR INDIVIDUAL PNEUMATIC AND ELECTRIC CATALOGS, OR VISIT STRAHMANGROUP.COM

# FS/FW SERIES 3-PC FIRESAFE BALL VALVES

## BILL OF MATERIALS

PART #	NAME	MATERIAL	QTY
1	BODY	WCB or CF8M	1
2	END CAP	WCB OR CF8M	2
3	BALL	CF8M	1
4	SEAT	RTFE	2
5	BODY SEAL	GRAPHITE	2
6	THRUST WASHER	GRAPHITE	1
7	STEM PACKING	GRAPHITE	1
8	GLAND	304SS	1
9	BELLEVILLE SPRING WASHER	301SS	2
10	STEM	316SS	1
11	NUT	304 SS	1
12	SPRING WASHER	304 SS	1
13	NUT	304 SS	1
14	BOLT	304 SS	4*
15	HANDLE	304 SS	1
16	HANDLE SLEEVE	VINYL	1
17	SADDLE WASHER	304 SS	1
18	O-RING	VITON	1
19	STOP PIN	304 SS	1
20	ANTI-STATIC DEVICE	304 SS	1

\* QTY 8 on 2" valve size

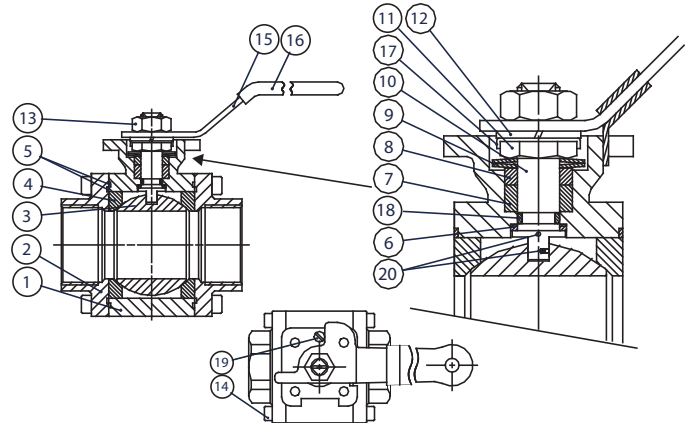
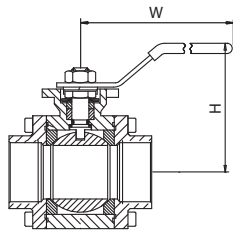
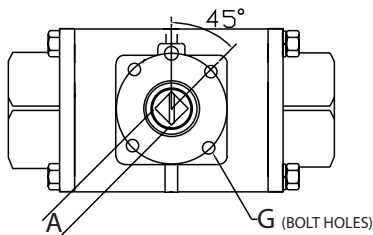

## VALVE FEATURES

- Full port 3-pc SS(FS) or WCB(FW) valve
- 1/4" through 2" size range
- NPT or socket weld ends
- RTFE® seats with graphoil seals
- Enclosed body bolts for extreme service
- ISO mounting pad
- API 607 4th edition fire safe

**PRESSURE RATING**  
 2000 PSI CWP  
 150 PSI Steam  
**TEMPERATURE RATING**  
 +350°F Maximum  
 -4°F Minimum

**NOTE: MAXIMUM TEMPERATURE RATING FOR STANDARD ACTUATORS IS 150°F (ELECTRIC) AND 180°F (PNEUMATIC). SPECIAL SEALS OR HEAT EXTENSIONS ARE AVAILABLE FOR HIGH TEMPERATURE SERVICE.**

## DIMENSIONAL DATA

SIZE	ISO 5211	A	D	E	F	G	H	K	M	S	W	CV	WT.
1/4"	F04	0.35	0.45	2.56	0.27	0.28	2.75	0.39	1.96	0.56	5.51	6.30	2.42
3/8"	F04	0.35	0.50	2.56	0.27	0.28	2.75	0.39	1.96	0.70	5.51	6.20	2.42
1/2"	F04	0.35	0.59	2.95	0.27	0.28	2.75	0.51	1.96	0.87	5.51	20.90	2.42
3/4"	F04-F05	0.43	0.79	3.15	0.31	0.28/0.35	3.54	0.59	2.2	1.08	7.08	49.40	3.55
1"	F04-F05	0.43	0.98	3.54	0.43	0.28/0.35	3.93	0.59	2.52	1.35	7.08	81.00	4.85
1-1/4"	F07	0.55	1.26	4.33	0.43	0.45	4.40	0.59	2.79	1.69	8.46	127.9	7.36
1-1/2"	F07	0.55	1.50	4.72	0.55	0.45	4.52	0.63	3.23	1.93	8.46	191.50	10.13
2"	F07	0.55	1.97	5.51	0.55	0.45	5.23	0.67	3.03	2.42	8.46	376	16.10

ALL VALVES ARE 100% ELECTRONICALLY TESTED AT 80 PSI IN BOTH THE OPEN AND CLOSED POSITIONS