

IS-3PT SERIES 3-PC STAINLESS BALL VALVES

PNEUMATIC ACTUATORS

PNEUMATIC FEATURES

- Rack and pinion design
- NAMUR accessory mounting on models 52 and higher
- Spring return and double acting
- Visual indicators
- Optional SS construction

ALL STANDARD ACTUATORS SIZED FOR 80 PSI AIR SUPPLY; PLEASE CONSULT FACTORY FOR OTHER COMBINATIONS

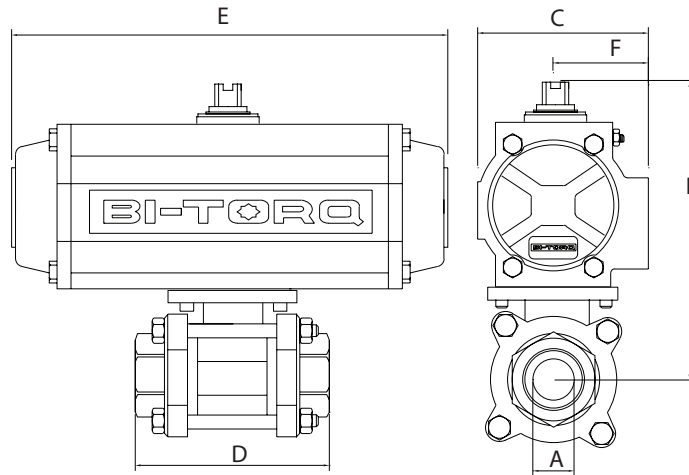

FOR A SELECTION OF AUTOMATION ACCESSORIES WE OFFER, REFER TO PAGE 31 OR VISIT STRAHMANGROUP.COM

DOUBLE ACTING ASSEMBLY DIMENSIONS							
A	B	C	D	E	F	ACT.	WT.
1/4"	4.25	1.77	2.56	4.65	0.89	32DA	2.32
3/8"	4.25	1.77	2.56	4.65	0.89	32DA	2.32
1/2"	4.25	1.77	2.95	4.65	0.89	32DA	2.50
3/4"	4.33	1.77	3.15	4.65	0.89	32DA	2.80
1"	5.61	2.79	3.54	5.49	1.61	52DA	5.40
1-1/4"	6.20	3.17	4.33	6.38	1.77	63DA	6.65
1-1/2"	6.64	3.17	4.72	6.38	1.77	63DA	9.95
2"	6.99	3.17	5.51	6.38	1.77	63DA	13.30
2-1/2"	8.96	4.17	7.28	9.35	2.30	85DA	28.80
3"	9.94	4.85	8.07	10.69	2.68	100DA	37.50
4"	12.18	5.39	9.45	12.91	2.87	115DA	69.10

SPRING RETURN ASSEMBLY DIMENSIONS							
A	B	C	D	E	F	ACT.	WT.
1/4"	5.21	2.79	2.56	5.49	1.61	52SR	3.92
3/8"	5.21	2.79	2.56	5.49	1.61	52SR	3.92
1/2"	5.21	2.79	2.95	5.49	1.61	52SR	4.10
3/4"	5.29	2.79	3.15	5.49	1.61	52SR	4.40
1"	6.05	3.17	3.54	6.38	1.77	63SR	7.05
1-1/4"	6.1	3.17	4.33	6.38	1.77	63SR	8.30
1-1/2"	7.29	3.72	4.72	8.15	2.07	75SR	13.70
2"	8.6	4.85	5.51	10.69	2.68	100SR	24.50
2-1/2"	10.65	5.39	7.28	12.91	2.87	115SR	43.65
3"	11.12	5.39	8.07	12.91	2.87	115SR	52.35
4"	16.22	7.35	9.45	16.93	3.94	161SR	105.3

ELECTRIC ACTUATORS

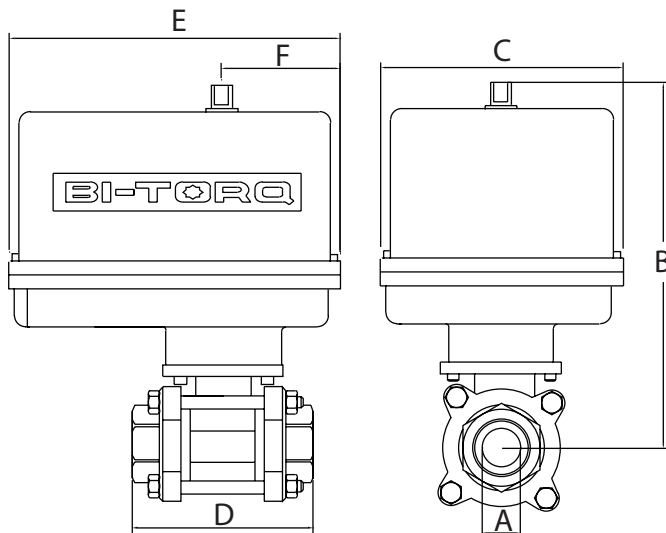

NEMA 4 ELECTRIC DIMENSIONS							
A	B	C	D	E	F	ACT.	WT.
1/4"	6.57	4.00	2.56	5.63	2.31	100E	6.27
3/8"	6.57	4.00	2.56	5.63	2.31	100E	6.27
1/2"	6.57	4.00	2.95	5.63	2.31	100E	6.45
3/4"	6.65	4.00	3.15	5.63	2.31	100E	6.75
1"	7.97	4.25	3.54	6.88	2.43	200E	10.10
1-1/4"	8.12	4.25	4.33	6.88	2.43	200E	11.35
1-1/2"	8.56	4.25	4.72	6.88	2.43	200E	13.65
2"	8.91	4.25	5.51	6.88	2.43	300E	17.00
2-1/2"	11.9*	7.00	7.28	7.00	2.38	675E	34.30
3"	12.37*	7.00	8.07	7.00	2.38	1000E	33.00
4"	20.06**	10.00	9.45	10.00	3.75	2000E	81.50

* DECLUTCHABLE MANUAL OVERRIDE INCLUDED IN DIMENSIONS
 ** MOUNTING KIT INCLUDED IN DIMENSIONS

ELECTRIC FEATURES

- 120VAC, 220VAC, 24VAC, 12VDC and 24VDC
- NEMA 4, 4X and 7 housings
- Manual overrides
- Visual indicators
- Open/close or modulating service

FOR NEMA 7 ELECTRIC DIMENSIONS OR OTHER CONFIGURATIONS, CONTACT OUR SALES STAFF.

FOR MORE INFORMATION ON BI-TORQ ACTUATORS, REFER TO OUR INDIVIDUAL PNEUMATIC AND ELECTRIC CATALOGS, OR VISIT STRAHMANGROUP.COM

IS-3PT SERIES 3-PC STAINLESS BALL VALVES

BILL OF MATERIALS

PART #	NAME	MATERIAL	QTY
1	ENDS	ASTM A351/GR CF8M	2
2	BODY SEAL	PTFE	1
3	BALL	316SS	1
4	BODY	ASTM A351/GR CF8M	1
5	SEAT	RTFE	2
6	WASHER	304SS	4
7	NUT	304SS	4
8	STEM SEAL	PTFE	1
9	O-RING	VITON	1
10	STEM PACKING	PTFE	1
11	BELLEVILLE WASHER	304SS	2
12	STEM NUT	304SS	1
13	STEM	316SS	1
14	BODY BOLT	304SS	4

2-1/2" AND LARGER MANUAL VALVES USE A BARSTOCK HANDLE

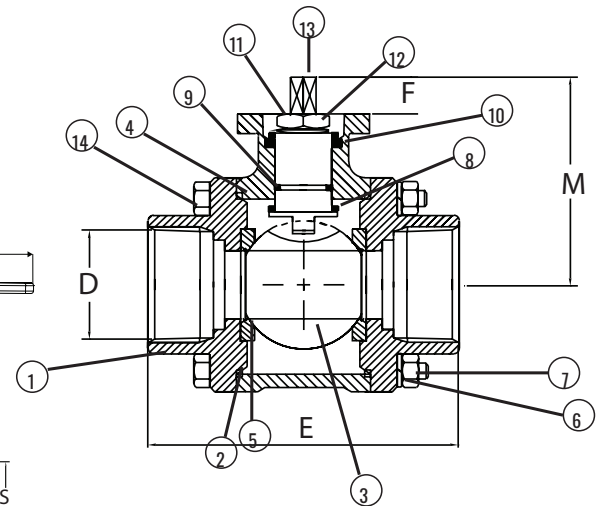
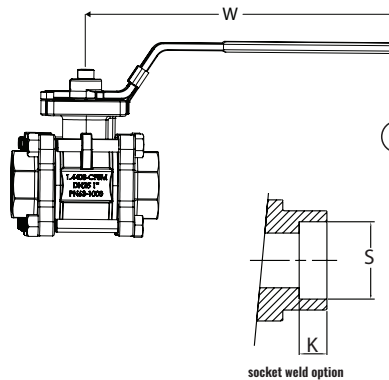
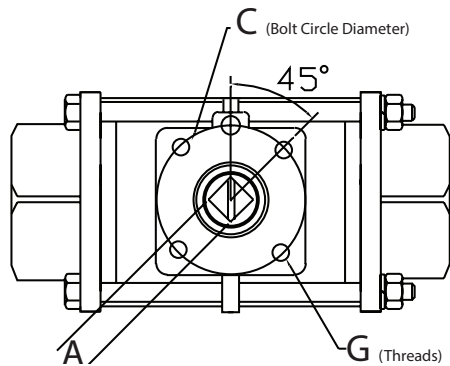

VALVE FEATURES

- Full port stainless steel valve
- 1/4" through 4" size range
- NPT, socket weld ends
- RTFE® seats/TFE seals
- Swing out design for easy maintenance
- ISO mounting pad

NOTE: NOT RECOMMENDED FOR USE IN OZONE SERVICE; PLEASE CONSULT FACTORY FOR RECOMMENDED VALVES

PRESSURE RATING
1000 PSI CWP
150 PSI Steam
TEMPERATURE RATING
+350°F Maximum
-4°F Minimum

NOTE: MAXIMUM TEMPERATURE RATING FOR STANDARD ACTUATORS IS 150°F (ELECTRIC) AND 180°F (PNEUMATIC). SPECIAL SEALS OR HEAT EXTENSIONS ARE AVAILABLE FOR HIGH TEMPERATURE SERVICE.

DIMENSIONAL DATA

SIZE	ISO 5211	A	C	D	E	F	G	K	M	S	W	CV	WT.
1/4"	F03-F04	0.35	1.42/1.65	0.45	2.56	0.27	0.22/0.28	0.40	1.96	0.56	5.25	4	1.27
3/8"	F03-F04	0.35	1.42/1.65	0.50	2.56	0.27	0.22/0.28	0.40	1.96	0.70	5.25	10	1.27
1/2"	F03-F04	0.35	1.42/1.65	0.59	2.95	0.27	0.22/0.28	0.50	1.96	0.87	5.25	24	1.45
3/4"	F03-F04	0.35	1.42/1.65	0.79	3.15	0.31	0.22/0.28	0.62	2.08	1.08	5.25	47	1.75
1"	F04-F05	0.43	1.65/1.97	0.98	3.54	0.43	0.28/0.35	0.69	2.52	1.35	7.50	81	3.10
1-1/4"	F04-F05	0.43	1.65/1.97	1.26	4.33	0.43	0.28/0.35	0.75	2.67	1.69	7.50	132	4.35
1-1/2"	F05-F07	0.55	1.97/2.76	1.50	4.72	0.55	0.28/0.35	0.88	3.23	1.93	8.25	202	6.65
2"	F05-F07	0.55	1.97/2.76	1.97	5.51	0.55	0.28/0.35	0.88	3.58	2.42	8.25	376	10.00
2-1/2"	F07-F10	0.67	2.76/4.02	2.50	7.28	0.67	0.28/0.35	0.88	4.57	3.04	12.00	642	21.30
3"	F07-F10	0.67	2.76/4.02	3.15	8.07	0.67	0.28/0.35	1.00	5.04	3.54	12.00	901	30.00
4"	F10-F12	0.87	4.02/4.92	3.82	9.45	0.87	0.35/0.50	1.26	6.30	4.54	N/A	1588	51.50

THE MANUAL VERSION OF THIS MODEL STARTS WITH AN "M"
ALL VALVES ARE 100% ELECTRONICALLY TESTED AT 80 PSI IN BOTH THE OPEN AND CLOSED POSITIONS