

IS-3WF SERIES FLANGED 3-WAY BALL VALVES

PNEUMATIC ACTUATORS

PNEUMATIC FEATURES

- Rack and pinion design
- NAMUR accessory mounting on models 52 and higher
- Spring return and double acting
- Visual indicators
- Optional SS construction

ALL STANDARD ACTUATORS SIZED FOR 80 PSI AIR SUPPLY; PLEASE CONSULT FACTORY FOR OTHER COMBINATIONS

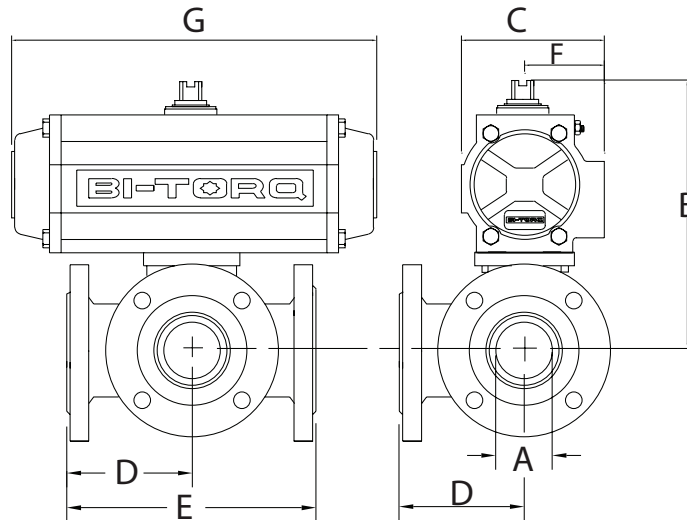

FOR A SELECTION OF AUTOMATION ACCESSORIES WE OFFER, REFER TO PAGE 31 OR VISIT STRAHMANGROUP.COM

DOUBLE ACTING ASSEMBLY DIMENSIONS								
A	B	C	D	E	F	G	ACT.	WT.
1/2"	5.17	2.79	2.99	5.98	1.61	5.49	52DA	10.3
3/4"	5.43	2.79	3.29	6.57	1.61	5.49	52DA	12.30
1"	5.71	2.79	3.74	7.48	1.61	5.49	52DA	17.30
1-1/4"	6.44	3.17	4.09	8.19	1.77	6.38	63DA	24.30
1-1/2"	7.50	3.72	4.33	8.66	2.07	8.15	75DA	31.30
2"	8.25	3.72	4.98	9.96	2.07	8.15	75DA	53.60
2-1/2"	11.44	5.39	5.91	11.81	2.87	12.91	115DA	72.60
3"	12.14	5.39	6.00	12.01	2.87	12.91	115DA	87.60
4"	12.93	5.39	7.26	14.53	2.87	12.91	115DA	135.6

SPRING RETURN ASSEMBLY DIMENSIONS								
A	B	C	D	E	F	G	ACT.	WT.
1/2"	5.17	2.79	2.99	5.98	1.61	5.49	52SR	10.70
3/4"	5.87	3.17	3.29	6.57	1.77	6.38	63SR	14.00
1"	6.80	3.72	3.74	7.48	2.07	8.15	75SR	22.00
1-1/4"	7.09	3.72	4.09	8.19	2.07	8.15	75SR	29.10
1-1/2"	8.46	4.85	4.33	8.66	2.68	10.69	100SR	43.50
2"	10.39	5.39	4.98	9.96	2.87	12.91	115SR	70.50
2-1/2"	11.91	5.83	5.91	11.81	3.15	14.41	125SR	74.50
3"	14.13	7.35	6.00	12.01	3.94	16.93	161SR	124.8
4"	14.92	7.35	7.26	14.53	3.94	16.93	161SR	173.8

ELECTRIC ACTUATORS

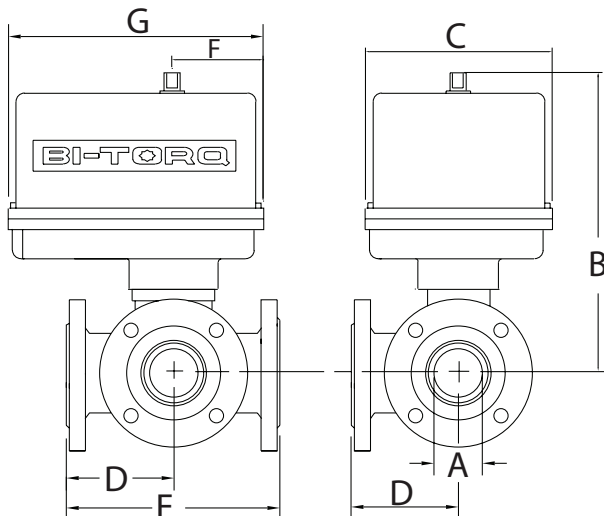

NEMA 4 ELECTRIC ASSEMBLY DIMENSIONS								
A	B	C	D	E	F	G	ACT.	WT.
1/2"	6.53	4.00	2.99	5.98	2.30	5.63	100E	13.00
3/4"	7.79	4.25	3.29	6.57	2.43	6.88	200E	17.00
1"	8.07	4.25	3.74	7.48	2.43	6.88	200E	22.00
1-1/4"	8.36	4.25	4.09	8.19	2.43	6.88	300E	29.00
1-1/2"	10.89*	7.00	4.33	8.66	2.38	7.00	400E	42.00
2"	11.64*	7.00	4.98	9.96	2.38	7.00	675E	61.00
2-1/2"	15.69*	7.00	5.91	11.81	2.38	7.00	1000E	73.00
3"	16.39*	7.00	6.00	12.01	2.38	7.00	1500E	89.00
4"	20.81**	10.00	7.26	14.53	3.75	10.00	2000E	155.00

* DECLUTCHABLE MANUAL OVERRIDE INCLUDED IN DIMENSIONS
 ** MOUNTING KIT INCLUDED IN DIMENSIONS

ELECTRIC FEATURES

- 120VAC, 220VAC, 24VAC, 12VDC and 24VDC
- NEMA 4, 4X and 7 housings
- Manual overrides
- Visual indicators
- Open/close or modulating service

FOR NEMA 7 ELECTRIC DIMENSIONS OR OTHER CONFIGURATIONS, CONTACT OUR SALES STAFF.

FOR MORE INFORMATION ON BI-TORQ ACTUATORS, REFER TO OUR INDIVIDUAL PNEUMATIC AND ELECTRIC CATALOGS, OR VISIT STRAHMANGROUP.COM

IS-3WF SERIES FLANGED 3-WAY BALL VALVES

BILL OF MATERIALS

PART #	NAME	MATERIAL	QTY
1	END CAP	CF8M	3
2	BODY	CF8M	1
3	BALL AND STEM	316SS	1
4	BUSHING	TFE	1
5	BALL SEAT	RTFE THRU 2"; TFE 2-1/2" THRU 4"	4
6	BODY SEAL	TFE	4
7	O-RING	VITON	1
8	STEM PACKING	TFE	1
9	PACKING GLAND	304SS	1
10	BELLEVILLE WASHER	301SS	2
11	GLAND NUT	304SS	1
12	HANDLE NUT	304SS	1
13	STOP PIN	304SS	1
14	HANDLE BOLT	304SS	1
15	HANDLE	304SS	1
16	BLIND CAP	CF8M	1
17 - 19	BOLTS AND NUTS	304SS	8
20	BONNET	CF8M	1
21	GASKET	TFE	1

NOTE: not suitable for vacuum service

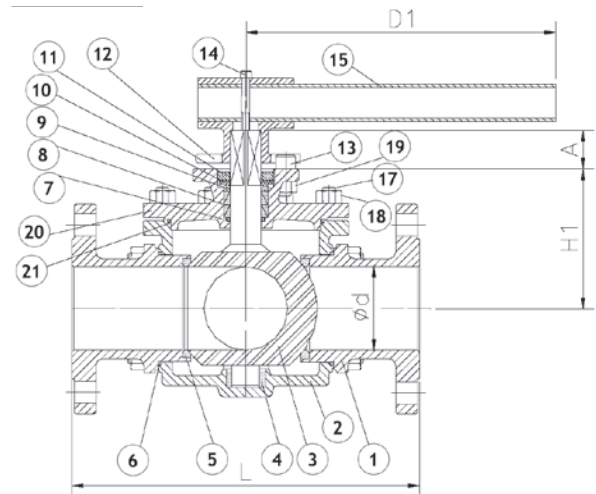
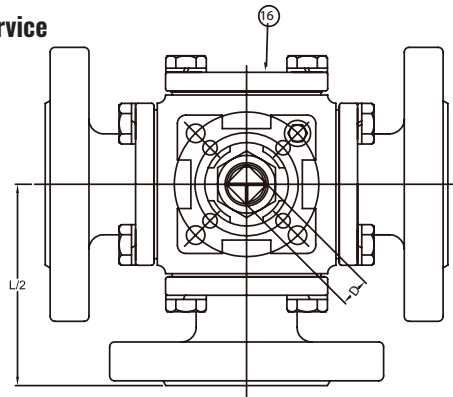

VALVE FEATURES

- 3-Way full port stainless steel valves
- 1/2" through 4" size range
- Ideal for mixing, food and chemical applications
- RTFE® seats through 2"; TFE 2-1/2" - 4"
- ANSI 150# Flanged
- 4-seat design for high cycle automation
- Self-adjusting stem packing w/belleville washers

PRESSURE RATING
ANSI Class 150
TEMPERATURE RATING
+350°F Maximum
-4°F Minimum

NOTE: MAXIMUM TEMPERATURE RATING FOR STANDARD ACTUATORS IS 150°F (ELECTRIC) AND 180°F (PNEUMATIC). SPECIAL SEALS OR HEAT EXTENSIONS ARE AVAILABLE FOR HIGH TEMPERATURE SERVICE.

See page 29 for possible pressure limitations due to flow patterns in certain applications with our floating ball valve design.

SEE PAGE 29 FOR AVAILABLE FLOW PATTERNS

DIMENSIONAL DATA

SIZE	ISO 5211	d	L	L2	H1	A	D1	D	WT.
1/2"	F03-F04	0.59	5.98	2.99	1.65	0.43	5.12	0.35	8.00
3/4"	F04-F05	0.79	6.57	3.29	1.91	0.55	6.50	0.43	10.0
1"	F04-F05	0.98	7.48	3.74	2.19	0.55	6.50	0.43	15.0
1-1/4"	F05-F07	1.26	8.19	4.09	2.48	0.67	8.07	0.55	22.0
1-1/2"	F05-F07	1.50	8.66	4.33	2.89	0.63	8.07	0.55	29.0
2"	F07-F10	1.97	9.96	4.98	3.64	0.83	12.80	0.67	48.0
2-1/2"	F10	2.44	11.81	5.91	4.69	0.98	15.75	0.87	55.0
3"	F10	2.99	12.01	6.00	5.39	0.98	19.69	0.87	71.0
4"	F10	3.78	14.53	7.26	6.18	0.98	23.62	0.87	118

THE MANUAL VERSION OF THIS MODEL STARTS WITH AN "M"

ALL VALVES ARE 100% ELECTRONICALLY TESTED AT 80 PSI IN BOTH THE OPEN AND CLOSED POSITIONS