

FS-3PT FIRE-SAFE 3-PIECE HIGH-PERFORMANCE BALL VALVE



PRESSURE RATING
2000 PSI (RTFE seats)
TEMPERATURE RATING
+450° F Maximum CWP
-40° F Minimum CWP

VALVE FEATURES

- Full port WCB/SS or all SS 3-piece ball valve
- ISO 5211 mounting pad for direct mount actuation
- API 607 Fire-Safe approved
- 1/4" through 2" sizes
- High-performance seat design
- Self-adjusting stem packing
- CRN, API and DIN certificates
- Swing-out 3-piece design for easy maintenance/repair
- NPT, butt weld or socket weld
- Female pipe threaded to NPT, DIN 259/2999, BS21 standards
- Inspection and testing to current API 598 standards
- Enclosed body bolt design for extreme service conditions

BILL OF MATERIALS

PART #	NAME	MATERIAL (STANDARD)	MATERIAL (OPTIONAL)	QTY
1	BODY	CF8M	WCB	1
2	END CAP	CF8M	WCB	2
3	BALL	CF8M	--	1
4	SEAT	PTFE	RTFE, DELRIN, PEEK, OR TFM	2
5	BODY SEAL	GRAPHITE	PTFE	2
6	THRUST WASHER	GRAPHITE	PTFE	1
7	STEM PACKING	GRAPHITE	--	1
8	GLAND	304 SS	--	1
9	BELLEVILLE SPRING WASHER	301 SS	--	2
10	STEM	316 SS	304 SS	1
11	NUT	304 SS	--	1
12	SPRING WASHER	304 SS	--	1
13	NUT	304 SS	--	1
14	BOLT	304 SS	--	4
15	HANDLE	304 SS	ZINC PLATED STEEL	1
16	HANDLE SLEEVE	VINYL	--	1
17	SADDLE WASHER	304 SS	--	1
18	O-RING	VITON	--	1
19	STOP PIN	304 SS	--	1
20	ANTI-STATIC DEVICE	304 SS	--	1

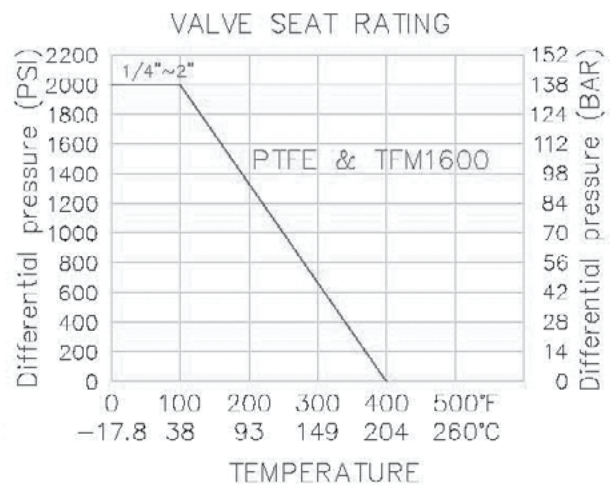
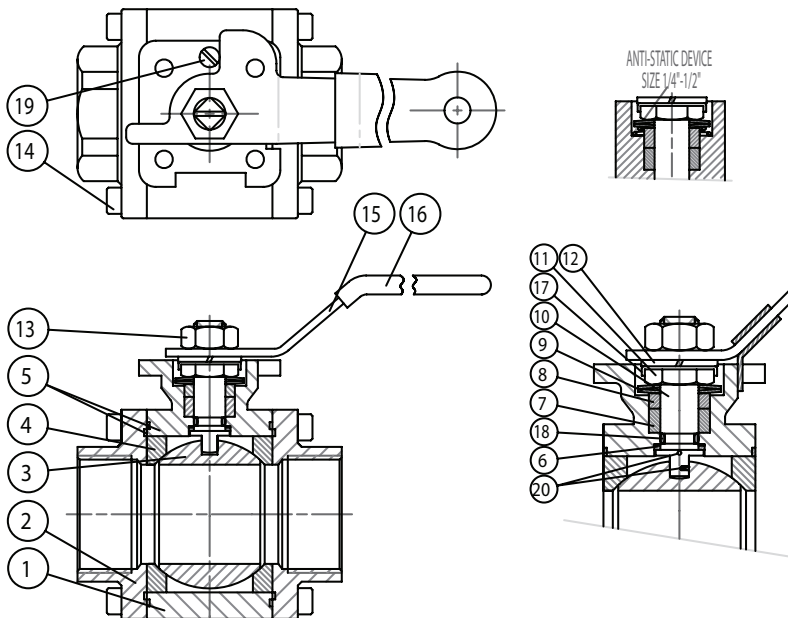

OPTIONAL ACCESSORIES INCLUDE:
FUSIBLE LINK ASSEMBLIES • DEADMAN HANDLES • GEAR OPERATORS

FS-3PT FIRE-SAFE 3-PIECE HIGH-PERFORMANCE BALL VALVE

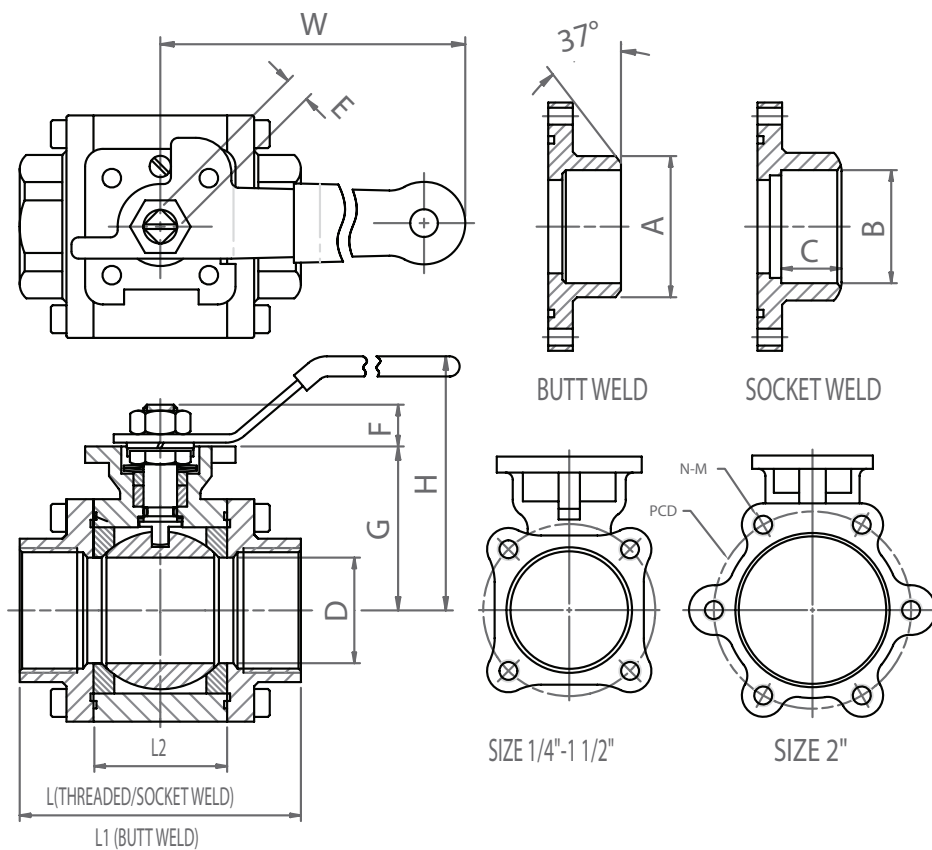

DIMENSIONAL DATA

SIZE	ISO 5211	D	L	L1	W	H	E	F	G	A	B	C	TORQUE (IN LBS)*	CV	WEIGHT (LBS.)
1/4"	F04	0.433	2.559	2.756	5.512	2.559	0.354	0.315	1.476	0.543	0.559	0.394	55	8	2.42
3/8"	F04	0.433	2.559	2.756	5.512	2.559	0.354	0.315	1.476	0.681	0.693	0.394	55	8	2.42
1/2"	F04	0.551	2.953	2.953	5.512	2.953	0.354	0.315	1.476	0.854	0.858	0.512	65	40	2.42
3/4"	F04/F05	0.807	3.149	3.543	7.087	3.149	0.433	0.433	2.047	1.071	1.071	0.591	85	70	3.55
1"	F04/F05	0.984	3.543	3.937	7.087	3.543	0.433	0.433	2.362	1.339	1.335	0.591	135	110	4.85
1-1/4"	F07	1.240	4.331	4.331	8.464	4.409	0.551	0.669	2.835	1.681	1.681	0.591	195	230	7.36
1-1/2"	F07	1.457	4.724	4.921	8.464	4.528	0.551	0.669	2.992	1.913	1.913	0.630	240	340	10.13
2"	F07	1.968	5.512	5.906	8.464	5.236	0.551	0.669	3.661	2.382	2.409	0.669	405	595	16.10

*with standard RTFE seats, 100 PSI clean service

VALVE SIZE	APPROX CV	EQUIVALENT LENGTH OF SCHEDULE 40 PIPE (FT.)	APPROXIMATE WEIGHT (LBS.)	TORQUE VALUE AT 100 PSI CLEAN SERVICE (RTFE SEATS)	TORQUE VALUE AT 100 PSI CLEAN SERVICE (DELIN SEATS)	TORQUE VALUE AT 100 PSI CLEAN SERVICE (PEEK SEATS)
1/2"	36	1.4	1.8	65	75	130
3/4"	71	1.0	3.0	85	98	170
1"	108	1.9	5.8	135	165	270
1-1/4"	230	2.1	6.4	195	255	390
1-1/2"	350	2.1	7.5	240	298	480
2"	600	2.1	29.1	405	500	810

**OPTIONAL ACCESSORIES INCLUDE:
FUSIBLE LINK ASSEMBLIES • DEADMAN HANDLES • GEAR OPERATORS**