

IP-3W SERIES 3-WAY BRASS BALL VALVES

PNEUMATIC ACTUATORS

PNEUMATIC FEATURES

- Rack and pinion design
- NAMUR accessory mounting on models 52 and higher
- Spring return and double acting
- Visual indicators
- Optional SS construction

ALL STANDARD ACTUATORS SIZED FOR 80 PSI AIR SUPPLY; PLEASE CONSULT FACTORY FOR OTHER COMBINATIONS

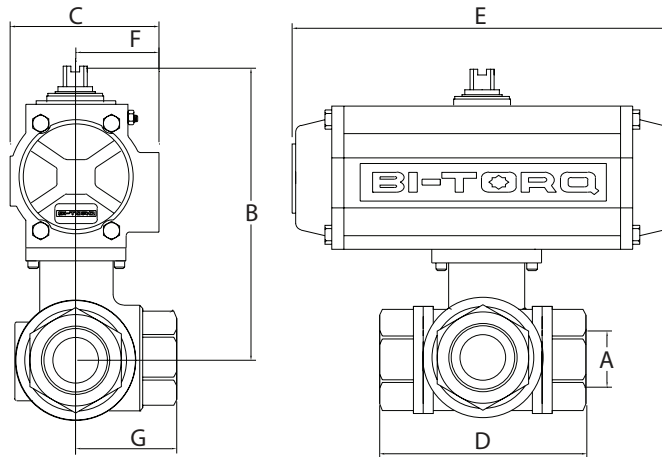

FOR A SELECTION OF AUTOMATION ACCESSORIES WE OFFER, REFER TO PAGE 31 OR VISIT STRAHMANGROUP.COM

DOUBLE ACTING ASSEMBLY DIMENSIONS								
A	B	C	D	E	F	G	ACT.	WT.
1/4"	3.76	1.77	2.64	4.65	0.89	1.32	32DA	2.02
3/8"	3.76	1.77	2.64	4.65	0.89	1.32	32DA	2.02
1/2"	3.76	1.77	2.87	4.65	0.89	1.44	32DA	2.20
3/4"	3.85	1.77	3.19	4.65	0.89	1.60	32DA	2.85
1"	5.15	2.79	3.74	5.49	1.61	1.87	52DA	5.63
1-1/4"	5.37	2.79	4.39	5.49	1.61	2.20	52DA	7.63
1-1/2"	5.51	3.17	4.86	6.38	1.77	2.43	63DA	11.96
2"	6.62	3.72	5.73	8.15	2.07	2.87	75DA	15.70
2-1/2"	7.07	3.72	6.93	8.15	2.07	3.47	75DA	21.93
3"	7.07	3.72	7.08	8.15	2.07	3.54	75DA	25.15

SPRING RETURN ASSEMBLY DIMENSIONS								
A	B	C	D	E	F	G	ACT.	WT.
1/4"	4.72	2.79	2.64	5.49	1.61	1.32	52SR	3.27
3/8"	4.72	2.79	2.64	5.49	1.61	1.32	52SR	3.27
1/2"	4.72	2.79	2.87	5.49	1.61	1.44	52SR	3.80
3/4"	4.81	2.79	3.19	5.49	1.61	1.60	52SR	4.45
1"	5.59	3.17	3.74	6.38	1.77	1.87	63SR	7.28
1-1/4"	5.81	3.17	4.39	6.38	1.77	2.20	63SR	9.28
1-1/2"	6.95	3.72	4.86	8.15	2.07	2.43	75SR	15.71
2"	7.96	4.17	5.73	9.35	2.30	2.87	85SR	19.6
2-1/2"	8.92	4.85	6.93	10.69	2.68	3.47	100SR	30.78
3"	8.92	4.85	7.08	10.69	2.68	3.54	100SR	34.00

ELECTRIC ACTUATORS

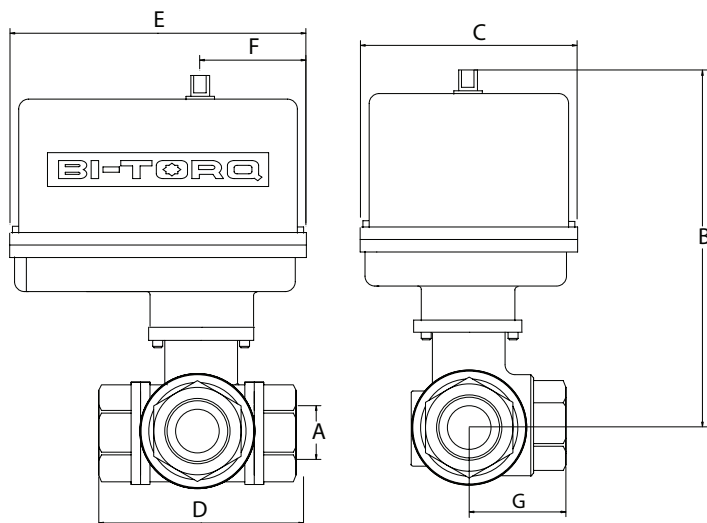

NEMA 4 ELECTRIC DIMENSIONS								
A	B	C	D	E	F	G	ACT.	WT.
1/4"	6.08	4.00	2.64	5.63	2.30	1.32	100E	5.97
3/8"	6.08	4.00	2.64	5.63	2.30	1.32	100E	5.97
1/2"	6.08	4.00	2.87	5.63	2.30	1.44	100E	6.15
3/4"	6.17	4.00	3.19	5.63	2.30	1.60	100E	6.80
1"	7.51	4.25	3.74	6.88	2.30	1.87	200E	10.33
1-1/4"	7.73	4.25	4.39	6.88	2.43	2.20	200E	12.33
1-1/2"	8.22	4.25	4.86	6.88	2.43	2.43	200E	15.66
2"	8.78	4.25	5.73	6.88	2.43	2.87	300E	17.10
2-1/2"	11.35*	7.00	6.93	7.00	2.38	3.47	400E	29.33
3"	11.35*	7.00	7.08	7.00	2.38	3.54	400E	32.55

NOTE: DECLUTCHABLE MANUAL OVERRIDE INCLUDED IN DIMENSIONS

ELECTRIC FEATURES

- 120VAC, 220VAC, 24VAC, 12VDC and 24VDC
- NEMA 4, 4X and 7 housings
- Manual overrides
- Visual indicators
- Open/close or modulating service

FOR NEMA 7 ELECTRIC DIMENSIONS OR OTHER CONFIGURATIONS, CONTACT OUR SALES STAFF.

FOR MORE INFORMATION ON BI-TORQ ACTUATORS, REFER TO OUR INDIVIDUAL PNEUMATIC AND ELECTRIC CATALOGS, OR VISIT STRAHMANGROUP.COM

IP-3W SERIES 3-WAY BRASS BALL VALVES

BILL OF MATERIALS

PART #	NAME	MATERIAL	QTY
1	BODY	BRASS UNI 5705-65	1
2	ENDS	BRASS UNI 5705-65	3
3	BALL	BRASS UNI 5705-65 CHROME PLATED	1
4	SEAT	TFE	4
5	BODY SEAL	VITON	4
6	STEM SEAL	TFE	1
7	BODY O-RING	VITON	1
8	STEM O-RING	VITON	1
9	STEM NUT	BRASS UNI 5705-65	1
10	STEM	BRASS UNI 5705-65	1

VALVE FEATURES

- Standard port brass valve
- 1/4" through 2"
- Multiple flow configurations
- TFE® seats and seals
- Viton® body o-rings
- ISO mounting pad
- Blowout proof stem
- 4-seat design

PRESSURE RATING
600 PSI CWP
TEMPERATURE RATING
+297°F Maximum

NOTE: MAXIMUM TEMPERATURE RATING FOR STANDARD ACTUATORS IS 150°F (ELECTRIC) AND 180°F (PNEUMATIC). SPECIAL SEALS OR HEAT EXTENSIONS ARE AVAILABLE FOR HIGH TEMPERATURE SERVICE.

SEE PAGE 31 FOR AVAILABLE FLOW PATTERNS

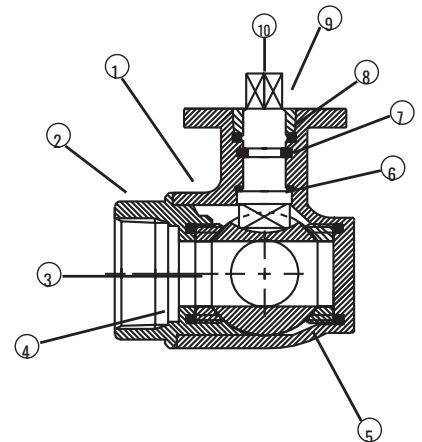
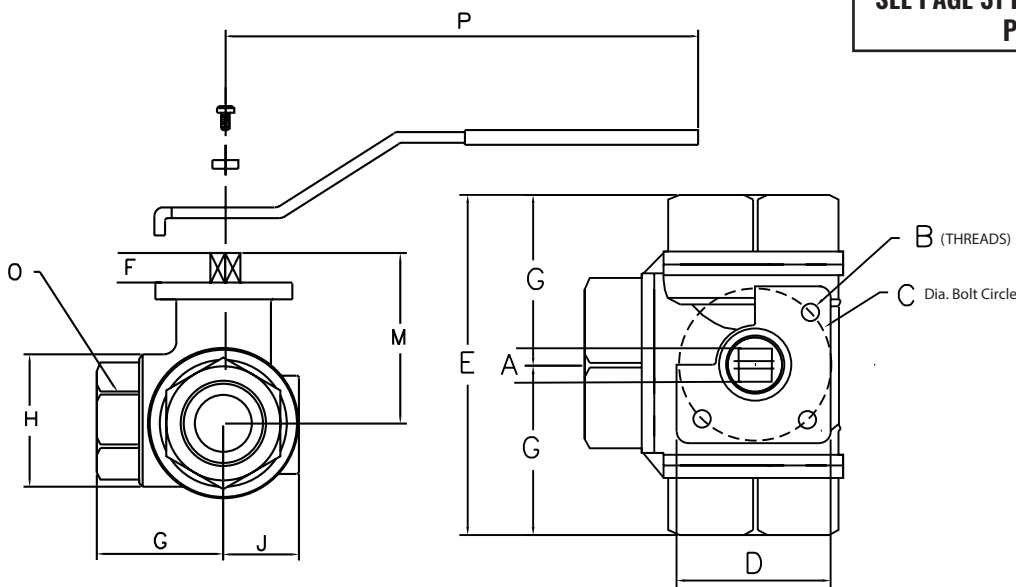

DIMENSIONAL DATA

SIZE	ISO 5211	A	B	C	D	E	F	G	H	J	M	O	P	CV	WT.
1/4"	F03	0.35	0.23	1.41	0.39	2.64	0.35	1.32	1.34	0.77	1.55	0.86	4.72	3.26	1.22
3/8"	F03	0.35	0.23	1.41	0.43	2.64	0.35	1.32	1.34	0.77	1.55	0.86	4.72	3.50	1.16
1/2"	F03	0.35	0.23	1.41	0.43	2.87	0.35	1.44	1.34	0.77	1.55	1.06	4.72	4.20	1.21
3/4"	F03	0.35	0.23	1.41	0.59	3.19	0.35	1.60	1.53	0.87	1.64	1.25	4.72	7.00	1.44
1"	F05	0.43	0.27	1.96	0.78	3.74	0.43	1.87	1.89	1.00	2.06	1.61	6.69	12.83	2.64
1-1/4"	F05	0.43	0.27	1.96	0.98	4.39	0.43	2.20	2.36	1.22	2.28	1.96	6.69	18.67	4.15
1-1/2"	F05	0.43	0.27	1.96	1.26	4.86	0.43	2.43	2.83	1.79	2.77	2.16	6.69	29.75	6.02
2"	F07	0.55	0.35	2.76	1.57	5.73	0.59	2.87	3.38	1.75	3.49	2.75	9.05	43.76	9.08
2-1/2"	F07	0.55	0.35	2.76	1.95	6.93	0.59	3.47	4.37	2.20	3.94	3.34	9.05	70.00	16.33
3"	F07	0.55	0.35	2.76	1.95	7.08	0.59	3.54	4.45	2.20	3.94	4.13	9.05	110	19.55

THE MANUAL VERSION OF THIS MODEL STARTS WITH AN "M"

ALL VALVES ARE 100% ELECTRONICALLY TESTED AT 80 PSI IN BOTH THE OPEN AND CLOSED POSITIONS