

# IS-3TC SERIES SANITARY CLAMP END BALL VALVES

## PNEUMATIC ACTUATORS

### PNEUMATIC FEATURES

- Rack and pinion design
- NAMUR accessory mounting on models 52 and higher
- Spring return and double acting
- Visual indicators
- Optional SS construction

ALL STANDARD ACTUATORS SIZED FOR 80 PSI AIR SUPPLY; PLEASE CONSULT FACTORY FOR OTHER COMBINATIONS

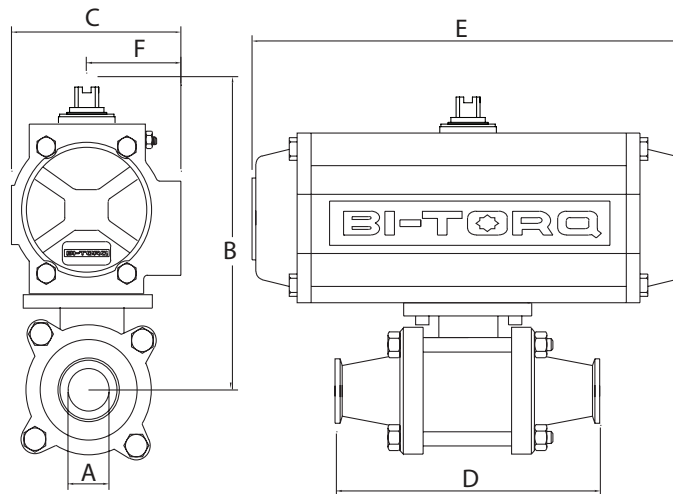

FOR A SELECTION OF AUTOMATION ACCESSORIES WE OFFER, REFER TO PAGE 31 OR VISIT [STRAHMANGROUP.COM](http://STRAHMANGROUP.COM)

DOUBLE ACTING ASSEMBLY DIMENSIONS							
A	B	C	D	E	F	ACT.	WT.
1/2"	4.25	1.78	3.50	4.65	0.89	32DA	2.65
3/4"	5.35	2.79	3.98	5.49	1.61	52DA	4.30
1"	5.94	3.17	4.49	6.38	1.77	63DA	5.25
1-1/2"	7.27	3.72	5.51	8.15	2.07	75DA	11.30
2"	7.58	3.72	6.14	8.15	2.07	75DA	14.6
2-1/2"	8.80	4.17	7.76	9.35	2.30	85DA	29.8
3"	9.70	4.85	9.02	10.69	2.68	100DA	46.35
4"	11.71	5.39	9.57	12.91	2.87	115DA	66.30

SPRING RETURN ASSEMBLY DIMENSIONS							
A	B	C	D	E	F	ACT.	WT.
1/2"	5.21	2.79	3.50	5.49	1.61	52SR	4.15
3/4"	5.79	3.17	3.98	6.38	1.77	63SR	5.95
1"	6.59	3.72	4.49	8.15	2.07	75SR	6.85
1-1/2"	8.23	4.85	5.51	10.69	2.68	100SR	20.15
2"	8.54	4.85	6.14	10.69	2.68	100SR	23.45
2-1/2"	10.49	5.39	7.76	12.91	2.87	115SR	46.65
3"	11.35	5.83	9.02	14.41	3.15	125SR	65.70
4"	13.70	8.82	9.57	16.93	3.94	161SR	103.5

## ELECTRIC ACTUATORS

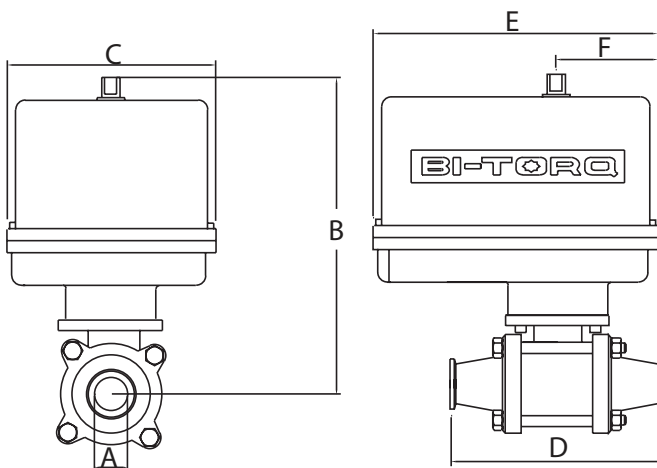

NEMA 4 ELECTRIC ASSEMBLY DIMENSIONS							
A	B	C	D	E	F	ACT.	WT.
1/2"	6.57	4.00	3.50	5.63	2.30	100E	6.40
3/4"	6.71	4.00	3.98	5.63	2.30	100E	7.00
1"	7.86	4.25	4.49	6.88	2.43	200E	9.90
1-1/2"	10.66*	7.00	5.51	7.00	2.38	400E	18.7
2"	10.97*	7.00	6.14	7.00	2.38	675E	22.00
2-1/2"	11.74*	7.00	7.76	7.00	2.38	1000E	37.30
3"	12.13*	7.00	9.02	7.00	2.38	1500E	48.20
4"	20.59*	10.00	9.57	10.00	3.75	2000E	80.70

\* DECLUTCHABLE MANUAL OVERRIDE INCLUDED IN DIMENSIONS

### ELECTRIC FEATURES

- 120VAC, 220VAC, 24VAC, 12VDC and 24VDC
- NEMA 4, 4X and 7 housings
- Manual overrides
- Visual indicators
- Open/close or modulating service

FOR NEMA 7 ELECTRIC DIMENSIONS OR OTHER CONFIGURATIONS, CONTACT OUR SALES STAFF.

FOR MORE INFORMATION ON BI-TORQ ACTUATORS, REFER TO OUR INDIVIDUAL PNEUMATIC AND ELECTRIC CATALOGS, OR VISIT [STRAHMANGROUP.COM](http://STRAHMANGROUP.COM)

# IS-3TC SERIES SANITARY CLAMP END BALL VALVES

## BILL OF MATERIALS

PART #	NAME	MATERIAL	QTY
1	END CAP	ASTM A351/GR CF8M	2
2	BODY SEAL	TFE	2
3	BALL	ASTM A351/316SS	1
4	BODY	ASTM A351/316SS	1
5	BALL SEAT	TFE	2
6	SPRING WASHER	304SS	1
7	GLAND NUT	304SS	1
8	STEM SEAL	TFE	1
9	O-RING	VITON	1
10	STEM PACKING	TFE	1
11	FOLLOWER	304SS	1
12	BELLEVILLE SPRING WASHERS	301SS	4
13	STEM NUT	304SS	1
14	STEM	316SS	1
15	BODY BOLT	304SS	4
16	HANDLE	304SS	1

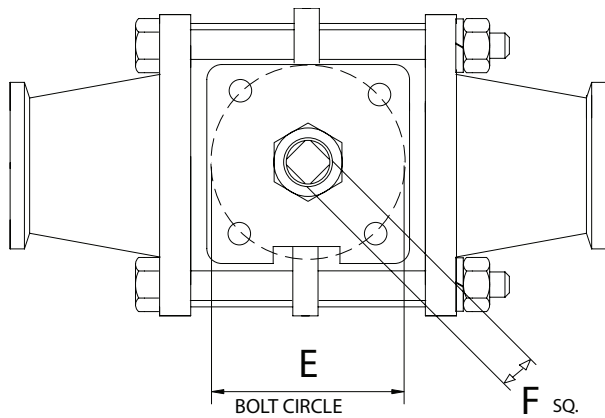

## VALVE FEATURES

- Full port sanitary valves
- 1/2" through 4"
- 240 grit bore polish
- Cavity filled TFE® seats to reduce the threat of media entrapment
- Swing out design for easy maintenance
- Polished clamp end to meet BS 4825.3

**PRESSURE RATING**  
 1000 PSI CWP (1/2" ~ 2")  
 800 PSI CWP (2-1/2" ~ 3")  
 600 PSI CWP (4")

**TEMPERATURE RATING**  
 +350°F Maximum  
 -4°F Minimum

**NOTE: MAXIMUM TEMPERATURE RATING FOR STANDARD ACTUATORS IS 150°F (ELECTRIC) AND 180°F (PNEUMATIC). SPECIAL SEALS OR HEAT EXTENSIONS ARE AVAILABLE FOR HIGH TEMPERATURE SERVICE.**

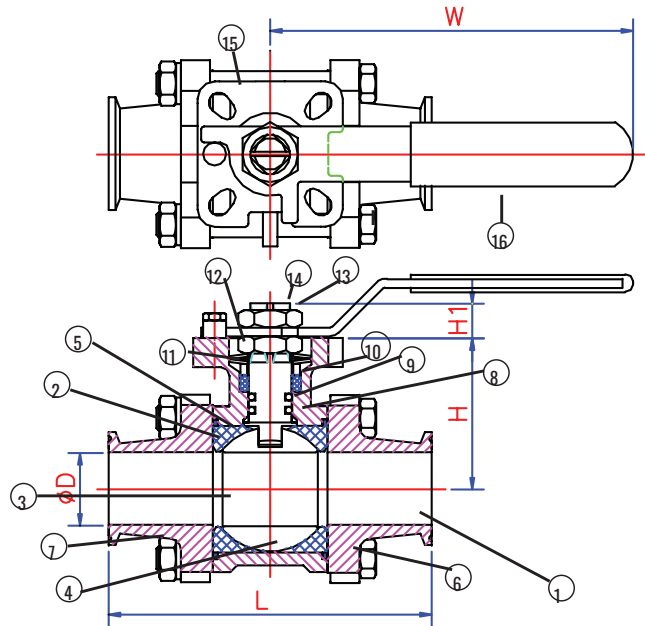

## DIMENSIONAL DATA

SIZE	ISO 5211	D	E	F	H	H1	L	W	CV	WT.
1/2"	F03-F04	0.37	1.42/1.65	0.35	1.69	0.354	3.50	4.57	14	1.40
3/4"	F03-F04	0.63	1.42/1.65	0.35	1.83	0.354	3.98	4.57	45	2.0
1"	F04-F05	0.87	1.65/1.97	0.43	1.98	0.443	4.49	6.14	81	2.90
1-1/2"	F05-F07	1.36	1.97/2.76	0.55	2.66	0.551	5.51	7.13	215	5.70
2"	F05-F07	1.87	1.97/2.76	0.55	2.97	0.551	6.14	7.13	410	9.00
2-1/2"	F07-F10	2.37	2.76/4.02	0.67	3.74	0.669	7.76	10.24	618	19.3
3"	F07-F10	2.87	2.76/4.02	0.67	4.13	0.669	9.02	10.24	940	31.2
4"	F10-F12	3.83	4.02/4.92	0.87	4.96	0.869	9.57	13.19	1840	43.7

**THE MANUAL VERSION OF THIS MODEL STARTS WITH AN "M"**  
 ALL VALVES ARE 100% ELECTRONICALLY TESTED AT 80 PSI IN BOTH THE OPEN AND CLOSED POSITIONS