

IS-3W SERIES 3-WAY BALL VALVES

PNEUMATIC ACTUATORS

PNEUMATIC FEATURES

- Rack and pinion design
- NAMUR accessory mounting on models 52 and higher
- Spring return and double acting
- Visual indicators
- Optional SS construction

ALL STANDARD ACTUATORS SIZED FOR 80 PSI AIR SUPPLY; PLEASE CONSULT FACTORY FOR OTHER COMBINATIONS

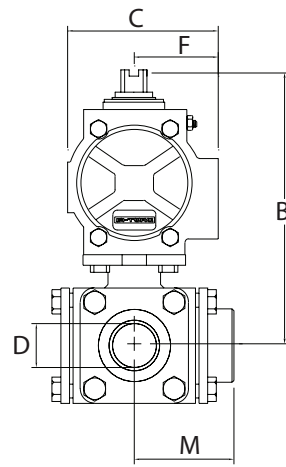
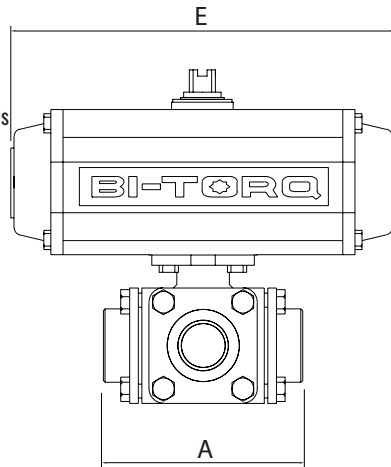

FOR A SELECTION OF AUTOMATION ACCESSORIES WE OFFER, REFER TO PAGE 31 OR VISIT STRAHMANGROUP.COM

DOUBLE ACTING ASSEMBLY DIMENSIONS								
D	A	B	C	E	F	M	ACT.	WT.
1/2"	3.78	5.40	2.79	5.49	1.61	1.89	52DA	6.2
3/4"	4.21	5.81	2.79	5.49	1.61	2.11	52DA	7.85
1"	4.96	6.04	2.79	5.49	1.61	2.48	52DA	11.85
1-1/4"	5.24	7.07	3.17	6.38	1.77	2.62	63DA	14.2
1-1/2"	5.94	8.09	3.72	8.15	2.07	2.97	75DA	24.05
2"	6.54	8.78	3.72	8.15	2.07	3.27	75DA	28.85

SPRING RETURN ASSEMBLY DIMENSIONS								
D	A	B	C	E	F	M	ACT.	WT.
1/2"	3.78	5.40	2.79	5.49	1.61	1.89	52SR	6.55
3/4"	4.21	6.25	3.17	6.38	1.77	2.11	63SR	9.6
1"	4.96	7.13	3.72	8.15	2.07	2.48	75SR	15.9
1-1/4"	5.24	7.72	3.72	8.15	2.07	2.62	75SR	18.95
1-1/2"	5.94	9.05	4.85	10.69	2.68	2.97	100SR	32.9
2"	6.54	10.92	5.39	12.91	2.87	3.27	115SR	45.6

ELECTRIC ACTUATORS

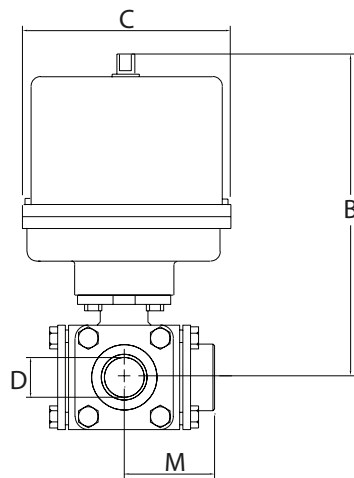
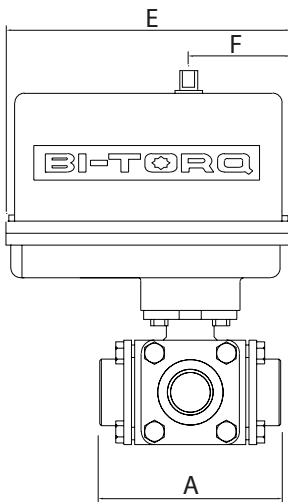

NEMA 4 ELECTRIC ASSEMBLY DIMENSIONS								
D	A	B	C	E	F	M	ACT.	WT.
1/2"	3.78	6.76	4.00	5.63	2.30	1.89	100E	8.90
3/4"	4.21	8.17	4.25	6.88	2.43	2.11	200E	12.65
1"	4.96	8.40	4.25	6.88	2.43	2.48	200E	15.85
1-1/4"	5.24	8.99	4.25	6.88	2.43	2.62	300E	18.9
1-1/2"	5.94*	11.48	7.00	7.00	2.38	2.97	400E	31.45
2"	6.54*	12.17	7.00	7.00	2.38	3.27	675E	34.25

* DECLUTCHABLE MANUAL OVERRIDE INCLUDED IN DIMENSIONS

ELECTRIC FEATURES

- 120VAC, 220VAC, 24VAC, 12VDC and 24VDC
- NEMA 4, 4X and 7 housings
- Manual overrides
- Visual indicators
- Open/close or modulating service

FOR NEMA 7 ELECTRIC DIMENSIONS OR OTHER CONFIGURATIONS, CONTACT OUR SALES STAFF.

FOR MORE INFORMATION ON BI-TORQ ACTUATORS, REFER TO OUR INDIVIDUAL PNEUMATIC AND ELECTRIC CATALOGS, OR VISIT STRAHMANGROUP.COM

IS-3W SERIES 3-WAY BALL VALVES

BILL OF MATERIALS

PART #	NAME	MATERIAL	QTY
1	BODY	316SS	1
2	END CONNECTION	316SS	3
3	BODY SEAL	PTFE	4
4	BALL	316SS	1
5	SEATS	RTFE	4
6	STEM	316SS	1
7	THRUST WASHER	PTFE	1
8	STEM PACKING	PTFE	1
9	GLAND	304SS	1
10	BELLEVILLE WASHER	304SS	2
11	PACKING NUT	304SS	1
12	SPRING WASHER	304SS	1
13	BODY BOLTS	304SS	1
14	BLANK CAP	316SS	1

VALVE FEATURES

- 3-Way full port stainless steel valves
- 1/2" through 2" size range
- Ideal for mixing, food and chemical applications
- RTFE® seats and seals
- Threaded or socket weld ends
- 4-seat design for high cycle automation
- Self-adjusting stem packing with belleville washers

PRESSURE RATING
 1000 PSI CWP
 150 PSI Steam
TEMPERATURE RATING
 +350°F Maximum
 -4°F Minimum

NOTE: MAXIMUM TEMPERATURE RATING FOR STANDARD ACTUATORS IS 150°F (ELECTRIC) AND 180°F (PNEUMATIC). SPECIAL SEALS OR HEAT EXTENSIONS ARE AVAILABLE FOR HIGH TEMPERATURE SERVICE.

See page 29 for possible pressure limitations due to flow patterns in certain applications with our floating ball valve design.

SEE PAGE 29 FOR AVAILABLE FLOW PATTERNS

NOTE: not suitable for vacuum service

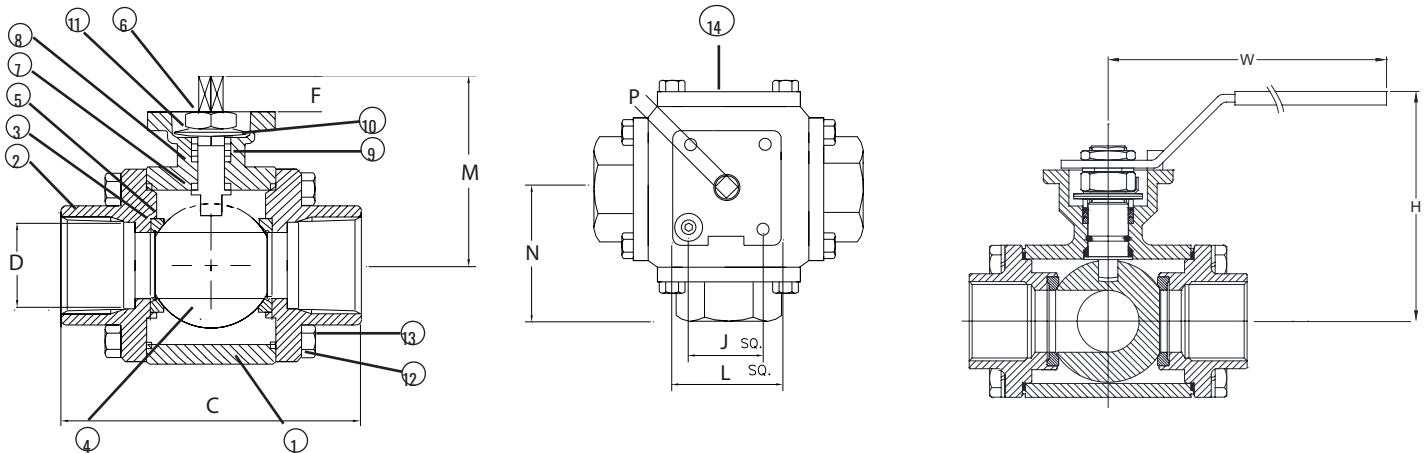

DIMENSIONAL DATA

SIZE	ISO 5211	B	C	D	F	J	L	M	N	P	W	H	WT.
1/2"	F03-F04	3.50	3.78	0.63	0.35	1.42	1.65	2.24	1.89	0.35	7.34	3.50	3.90
3/4"	F04-F05	3.86	4.21	0.79	0.43	1.65	1.97	2.72	2.11	0.43	8.58	3.86	5.65
1"	F04-F05	4.02	4.96	0.98	0.45	1.65	1.97	2.97	2.48	0.43	8.58	4.02	8.85
1-1/4"	F05-F07	4.67	5.24	1.26	0.60	1.97	2.76	3.71	2.62	0.55	9.25	4.67	11.90
1-1/2"	F05-F07	5.00	5.94	1.50	0.56	1.97	2.76	4.05	2.97	0.55	9.25	5.00	18.45
2"	F07-F10	5.47	6.54	1.97	0.70	2.76	4.02	4.87	3.27	0.67	9.92	5.47	23.25

THE MANUAL VERSION OF THIS MODEL STARTS WITH AN "M"
 ALL VALVES ARE 100% ELECTRONICALLY TESTED AT 80 PSI IN BOTH THE OPEN AND CLOSED POSITIONS