



# MANUALLY OPERATED BALL VALVES

BRASS. STAINLESS, SANITARY & FIRE-SAFE BALL VALVES



# MP-2P 2 PIECE FULL PORT BRASS BALL VALVE



**PRESSURE RATING**  
600WOG  
**TEMPERATURE RATING**  
+320° F Maximum CWP  
100PSI Steam Maximum

## VALVE FEATURES

- Full port brass ball valve
- 1/4" through 4"
- Blow-out proof stem
- Chrome plated brass ball
- Adjustable stem packing
- ANSI B 1.20.1 connections
- CSA, UL, NSF and FM approved through 2"

## BILL OF MATERIALS

PART #	NAME	MATERIAL	QTY
1	BODY	BRASS CW 617N UNI EN 12165	1
2	ENDS	BRASS CW 617N UNI EN 12165	2
3	BALL	BRASS CW 617N UNI EN 12165	1
4	SEAT	PTFE	2
5	STEM SEAL	PTFE	2
6	O-RING	NBR 75Sh A	1
7	PACKING GLAND	BRASS CW 614N UNI EN 12164	1
8	NUT	STEEL NS6	1
9	STEM	BRASS CW 614N UNI EN 12164	1
10	LEVER HANDLE	PLATED STEEL*	1

\*2-1/2" THROUGH 4" SIZE USES ALUMINUM HANDLE

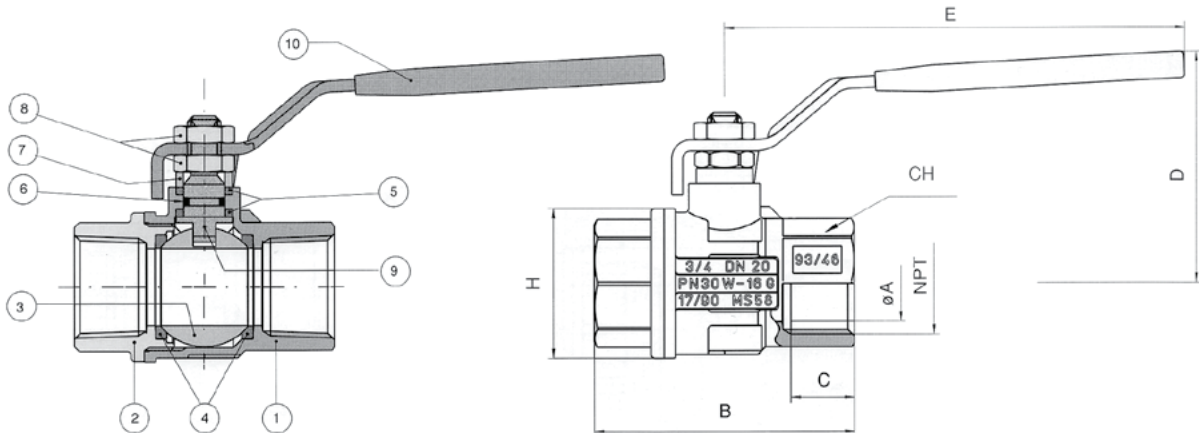

## DIMENSIONAL DATA

SIZE	A	B	C	D	E	H	CH	CV	PSI	WEIGHT (LBS.)
1/4"	0.39	2.02	0.39	1.75	3.85	0.90	0.78	6.29	600	0.30
3/8"	0.39	2.02	0.40	1.75	3.85	0.90	0.78	6.99	600	0.38
1/2"	0.59	2.44	0.53	1.88	3.85	1.25	0.98	19.00	600	0.48
3/4"	0.78	2.71	0.55	2.28	4.80	1.53	1.22	34.42	600	0.79
1"	0.98	3.07	0.66	2.44	4.80	1.92	1.49	50.10	600	1.22
1-1/4"	1.25	3.42	0.68	3.07	6.02	2.32	1.88	103.70	600	2.14
1-1/2"	1.57	3.89	0.68	3.34	6.02	2.87	2.12	268.41	600	3.20
2"	1.96	4.33	0.69	3.79	6.37	3.38	2.63	309.20	600	4.08
2-1/2"	2.56	5.59	1.19	5.02	8.07	4.37	3.54	629.00	600	8.28
3"	3.15	6.45	1.31	5.45	8.07	5.35	4.13	1018.00	600	13.00
4"	3.94	7.60	1.55	6.34	10.23	6.35	5.12	1622.00	600	22.07

**OPTIONAL ACCESSORIES INCLUDE:**  
**FUSIBLE LINK ASSEMBLIES • DEADMAN HANDLES • GEAR OPERATORS**

# MP-3W 3-WAY BRASS BALL VALVE



**PRESSURE RATING**  
400WOG  
**TEMPERATURE RATING**  
+320° F Maximum CWP  
100PSI Steam Maximum

## VALVE FEATURES

- 3-way brass ball valve
- 1/4" through 3"
- Blow-out proof stem
- Chrome plated brass ball
- PTFE seats with O-ring backing for low torque
- T-port or L-port design
- ISO 5211 mounting pad

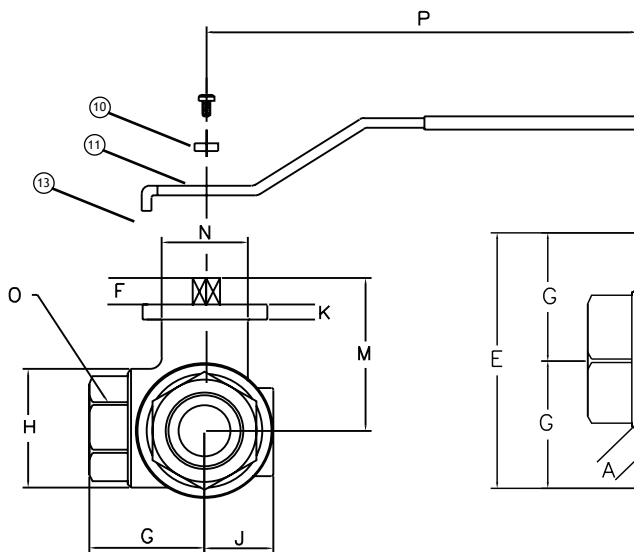

BILL OF MATERIALS			
PART #	NAME	MATERIAL	QTY
1	BODY	BRASS CW 617N UNI EN 12165	1
2	ENDS	BRASS CW 617N UNI EN 12165	3
3	BALL	BRASS CW 617N UNI EN 12165	1
4	SEAT	PTFE	4
5	THRUST WASHER	PTFE	1
6	STEM SEAL	PTFE	1
7	PACKING NUT	BRASS CW 614N UNI EN 12164	1
8	O-RING (STEM)	FKM (VITON®)	1
9	O-RING (BODY)	FKM (VITON®)	4
10	SCREW	PLATED STEEL	1
11	BUSHING	BRASS CW 617N UNI EN 12165	1
12	STEM	BRASS CW 617N UNI EN 12165	1
13	LEVER HANDLE	PLATED STEEL	1

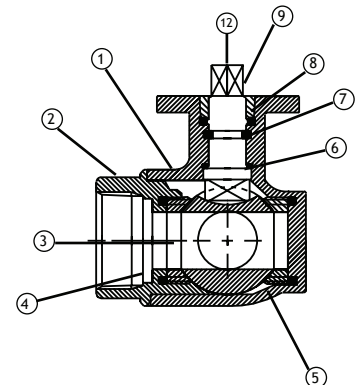

## DIMENSIONAL DATA

SIZE	A	B	C	D	E	F	G	H	J	K	M	O	P	CV	PSI	WEIGHT (LBS.)
1/4"	0.354	0.23	1.42 (F03)	1.49	2.63	0.27	1.31	1.34	0.76	0.20	2.44	0.86	4.72	3.26	400	1.16
3/8"	0.354	0.23	1.42 (F03)	1.49	2.63	0.27	1.31	1.34	0.76	0.20	2.44	0.86	4.72	3.26	400	1.16
1/2"	0.354	0.23	1.42 (F03)	1.49	2.87	0.27	1.43	1.34	0.76	0.20	2.44	1.06	4.72	4.20	400	1.21
3/4"	0.354	0.23	1.42 (F03)	1.49	3.18	0.27	1.59	1.53	0.86	0.20	2.52	1.25	4.72	7.00	400	1.44
1"	0.433	0.27	1.97 (F05)	2.07	3.74	0.43	1.87	1.89	1.00	0.28	2.95	1.61	6.69	12.83	400	2.64
1-1/4"	0.433	0.27	1.97 (F05)	2.07	4.38	0.43	2.20	2.36	1.22	0.28	3.17	1.96	6.69	18.67	400	4.15
1-1/2"	0.433	0.27	1.97 (F05)	2.07	4.86	0.43	2.43	2.83	1.48	0.28	3.66	2.16	6.69	29.75	400	6.02
2"	0.551	0.35	2.76 (F07)	2.75	5.70	0.59	2.86	3.38	1.75	0.32	4.43	2.75	9.05	43.76	400	9.08
2-1/2"	0.551	0.35	2.76 (F07)	2.75	6.93	0.59	3.34	4.37	2.20	0.32	4.86	3.34	9.05	70	400	16.33
3"	0.551	0.35	2.76 (F07)	2.75	7.08	0.59	3.54	4.45	2.20	0.32	4.86	4.13	9.05	70	400	19.55

**OPTIONAL ACCESSORIES INCLUDE:**  
FUSIBLE LINK ASSEMBLIES • DEADMAN HANDLES • GEAR OPERATORS

# MS-2PF 2 PIECE FLANGED STAINLESS STEEL BALL VALVE



**PRESSURE RATING**  
Class 150 flanged  
**TEMPERATURE RATING**  
+450° F Maximum  
366° F Steam Maximum

## VALVE FEATURES

- ANSI 150# flanged SS valve
- 1/2" through 4"
- Blow-out proof stem
- RTFE seats and seals
- designed to ANSI B16.34 flange standards
- self-adjusting stem packing
- ISO 5211 mounting pad

## BILL OF MATERIALS

PART #	NAME	MATERIAL	QTY
1	BODY	ASTM A351 CF8M	1
2	ENDS	ASTM A351 CF8M	2
3	BALL	ASTM A351 CF8M	1
4	SEAT	RTFE	2
5	BODY SEAL	RTFE	2
6	STEM	ASTM A276 TYPE 316	1
7	THRUST WASHER	50% TFE + 50% SS POWDER	1
8	STEM PACKING	PTFE	1
9	O-RING	FKM (VITON®)	1
10	BELLEVILLE WASHER	304SS	1
11	PACKING NUT	304SS	1
12	LOCK WASHER	304SS	1
13	HANDLE WASHER	304SS	1
14	HANDLE NUT	304SS	1
15	HANDLE	304SS	1
16	STEM	ASTM A276 TYPE 316	1

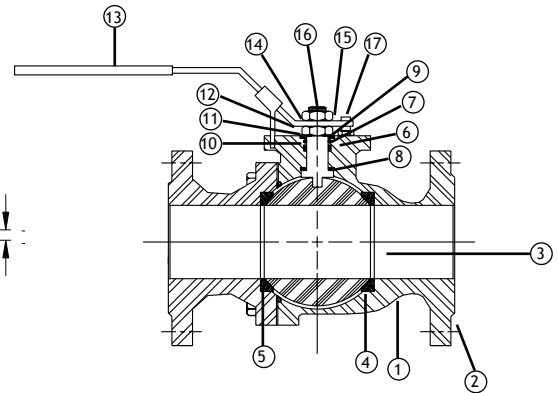
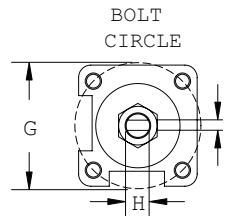
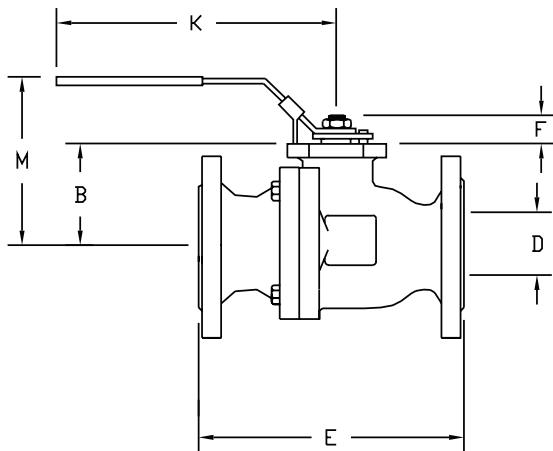

## DIMENSIONAL DATA

SIZE	ISO 5211	B	D	E	F	G	H	I	K	M	CV	PSI	WEIGHT (LBS.)
1/2"	F04	1.51	0.59	4.25	0.24	1.42	0.248	0.472	5.90	3.53	15	275	4
3/4"	F04	1.63	0.78	4.62	0.24	1.42	0.248	0.472	5.90	3.88	40	275	6
1"	F05	1.96	0.98	5.00	0.31	1.97	0.315	0.511	7.08	4.25	70	275	8
1-1/4"	F05	1.97	1.25	5.50	0.37	1.97	0.315	0.511	7.08	4.62	130	275	12
1-1/2"	F07	2.61	1.57	6.50	0.37	2.76	0.374	0.525	8.26	5.00	240	275	16
2"	F07	2.95	1.96	7.00	0.37	2.76	0.374	0.525	8.26	6.00	400	275	21
2-1/2"	F07	3.52	2.55	7.50	0.66	2.76	0.669	1.140	10.23	7.00	700	275	38
3"	F10	4.23	3.14	8.00	0.66	4.02	0.669	1.140	10.23	7.50	980	275	46
4"	F10	4.84	3.93	9.00	0.66	4.02	0.669	1.140	12.20	9.00	1700	275	73

**OPTIONAL ACCESSORIES INCLUDE:**  
**FUSIBLE LINK ASSEMBLIES • DEADMAN HANDLES • GEAR OPERATORS**

# MS-2PF 2 PIECE STAINLESS STEEL BALL VALVE



**PRESSURE RATING**  
1000PSI  
**TEMPERATURE RATING**  
+450° F Maximum CWP  
366° F Steam Maximum

## VALVE FEATURES

- Full port SS valve
- 1/4" through 3"
- Blow-out proof stem
- RTFE seats and TFE seals
- spring loaded belleville washers
- adjustable stem packing
- ISO 5211 mounting pad for direct mount actuation

## BILL OF MATERIALS

PART #	NAME	MATERIAL	QTY
1	BODY	ASTM A351 CF8M	1
2	ENDS	ASTM A351 CF8M	2
3	BALL	316SS	1
4	SEAT	RTFE	2
5	BODY SEAL	PTFE	2
6	STEM	316SS	1
7	THRUST WASHER	PTFE	1
8	STEM PACKING	PTFE	1
9	GLAND NUT	304SS	1
10	BELLEVILLE WASHER	304SS	2
11	PACKING NUT	304SS	1
12	LOCK WASHER	304SS	1
13	HANDLE NUT	304SS	1
14	HANDLE	304SS	1

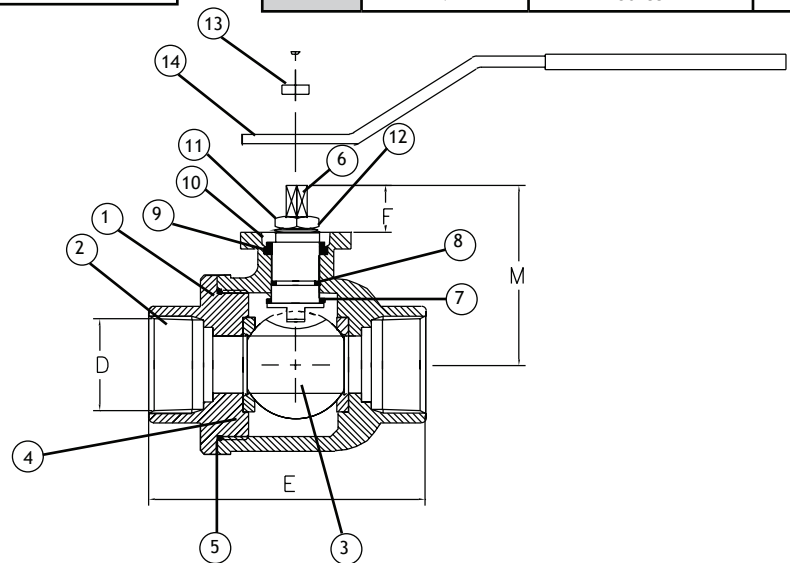
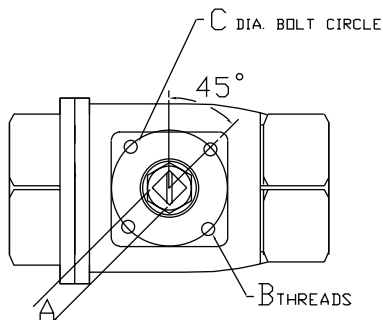

## DIMENSIONAL DATA

SIZE	ISO 5211	A	B	C	D	E	F	M	CV	PSI	WEIGHT (LBS.)
1/4"	F03-F04	0.354	0.28	1.42/1.65	0.45	2.56	0.29	1.98	10	1000	0.88
3/8"	F03-F04	0.354	0.28	1.42/1.65	0.48	2.56	0.29	1.98	12	1000	0.88
1/2"	F03-F04	0.354	0.28	1.42/1.65	0.59	2.95	0.34	1.98	15	1000	0.95
3/4"	F03-F04	0.354	0.28	1.42/1.65	0.79	3.15	0.34	2.08	38	1000	1.45
1"	F04-F05	0.433	0.28	1.65/1.97	1.00	3.54	0.43	2.42	65	1000	2.36
1-1/4"	F04-F05	0.433	0.28	1.65/1.97	1.25	4.33	0.43	2.62	118	1000	3.50
1-1/2"	F05-F07	0.551	0.28/0.35	1.97/2.76	1.50	4.72	0.55	3.14	195	1000	4.21
2"	F05-F07	0.551	0.28/0.35	1.97/2.76	1.97	5.51	0.55	3.69	320	1000	7.90
2-1/2"	F07-F10	0.669	0.35	2.76/4.02	2.56	7.28	0.70	3.90	386	1000	17.60
3"	F07-F10	0.669	0.35	2.76/4.02	3.15	8.07	0.70	4.37	600	1000	25.30

**OPTIONAL ACCESSORIES INCLUDE:**  
**FUSIBLE LINK ASSEMBLIES • DEADMAN HANDLES • GEAR OPERATORS**

# MS-3TC 3 PIECE SANITARY CLAMP END STAINLESS STEEL BALL VALVE



**PRESSURE RATING**  
1000PSI  
**TEMPERATURE RATING**  
+450° F Maximum CWP  
366° F Steam Maximum

## VALVE FEATURES

- Full port SS valve
- 1/2" through 4"
- 240 grit bore polish
- cavity filled TFE seats to prevent product entrapment
- swing-out 3-piece design for easy maintenance
- polished clamp end
- ISO 5211 mounting pad for direct mount actuation (1/2"-2")

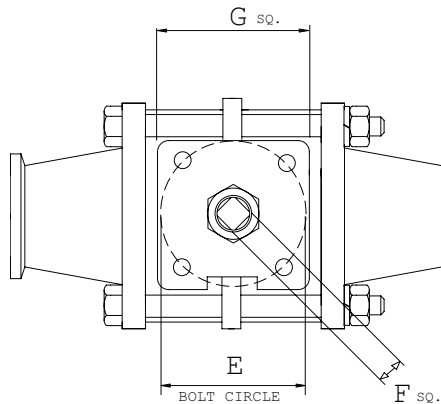

BILL OF MATERIALS			
PART #	NAME	MATERIAL	QTY
1	BODY	ASTM A351 CF8M	1
2	ENDS	ASTM A351 CF8M	2
3	BALL	316SS	1
4	SEAT	PTFE	2
5	BODY SEAL	VITON®	2
6	THRUST BEARING	PTFE	1
7	STEM PACKING	PTFE	1
8	GLAND NUT	304SS	1
9	WASHER	304SS	1
10	HANDLE NUT	304SS	1
11	STEM	316SS	1
12	BOLT WASHER	304SS	1
13	NUT	304SS	1
14	BOLT	304SS	1

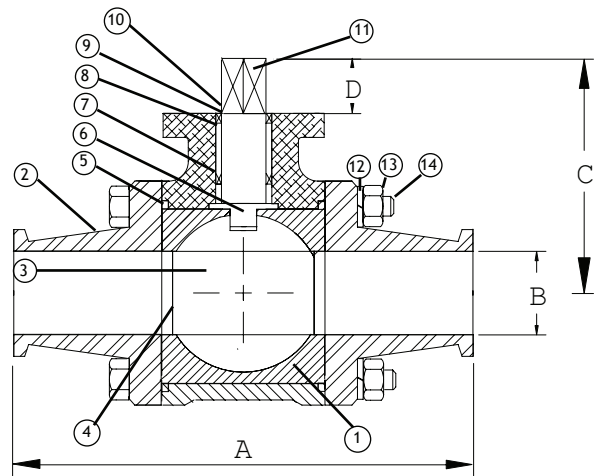

## DIMENSIONAL DATA

SIZE	ISO 5211	A	B	C	D	E	F	G	CV	PSI	WEIGHT (LBS.)
1/2"	F03-F04	4.33	0.37	2.05	0.354	1.42/1.65	0.354	1.46	14	1000	1.4
3/4"	F03-F04	4.68	0.63	2.24	0.354	1.42/1.65	0.354	1.46	45	1000	2.0
1"	F04-F05	4.88	0.87	2.36	0.433	1.65/1.97	0.433	1.87	81	1000	2.9
1-1/2"	F05-F07	5.55	1.37	3.54	0.551	1.97/2.76	0.551	2.20	215	1000	5.7
2"	F05-F07	6.37	1.87	5.51	0.551	1.97/2.76	0.551	2.20	410	1000	9.0
2-1/2"	F07	7.76	2.07	5.91	1.750	2.76	0.472 (FLATS) 0.787 (ROUND)	3.15	618	1000	19.3
3"	F07	9.02	2.87	6.10	1.750	2.76	0.472 (FLATS) 0.787 (ROUND)	3.15	940	1000	31.2
4"	F10	9.49	3.83	7.09	1.950	4.02	0.590 (FLATS) 1.140 (ROUND)	4.26	1840	1000	43.7

**OPTIONAL ACCESSORIES INCLUDE:**  
**FUSIBLE LINK ASSEMBLIES • DEADMAN HANDLES • GEAR OPERATORS**

# ED50 OR W50 API 607 FIRE SAFE FLANGED BALL VALVE

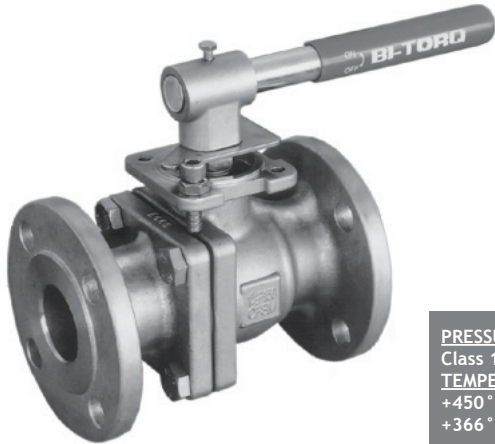

**PRESSURE RATING**  
Class 150 flanged  
**TEMPERATURE RATING**  
+450° F Maximum CWP  
+366° F Steam Maximum

## VALVE FEATURES

- Full port stainless steel ball valve or carbon steel
- 1/2" through 4"
- Class 150# flanged designed to ANSI B16.34
- API607 fire safe approved
- ISO mounting pad for easy automation
- Self-adjusting stem packing
- DIN 50049-3.1B certificate

## BILL OF MATERIALS

PART #	NAME	MATERIAL	QTY
1	BODY	ASTM A351 GR CF8M (ED50) ----- WCB (W50)	1
2	ENDS	ASTM A351 GR CF8M	2
3	BALL	ASTM A351 GR CF8M	1
4	SEAT	PTFE	2
5	BODY SEAL	SS304 SPIRAL WOUND	2
6	STEM SEAL	GRAPHOIL	1
7	STEM PACKING	GRAPHOIL	1
8	THRUST WASHER	50% PTFE + 50% SS POWDER	1
9	GLAND	304SS	1
10	BELLEVILLE WASHER	304SS	2
11	LOCK WASHER	304SS	1
12	STEM NUT	304SS	1
13	HANDLE	304SS	1

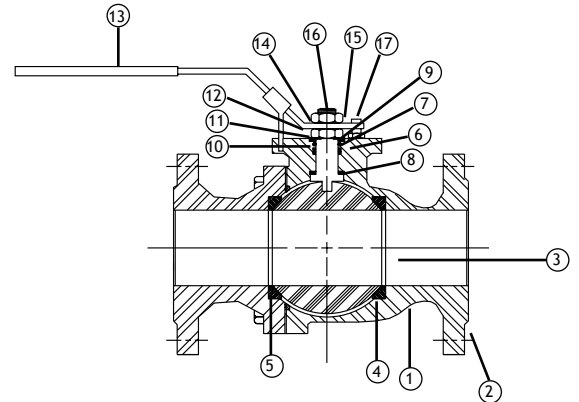
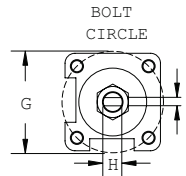
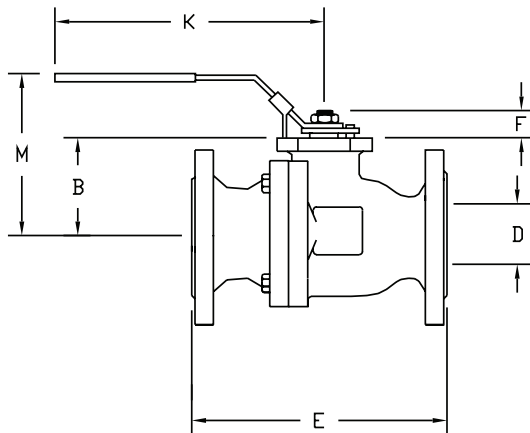

## DIMENSIONAL DATA

SIZE	ISO 5211	B	D	E	F	G	H	I	K	M	CV	TORQUE	WEIGHT (LBS.)
1/2"	F04	1.51	0.59	4.25	0.24	1.42	0.248	0.472	5.90	3.53	15	88	4
3/4"	F04	1.63	0.78	4.62	0.24	1.42	0.248	0.472	5.90	3.88	40	106	6
1"	F05	1.96	0.98	5.00	0.31	1.97	0.315	0.511	7.08	4.25	70	132	8
1-1/4"	F05	1.97	1.25	5.50	0.37	1.97	0.315	0.511	7.08	4.62	130	256	12
1-1/2"	F07	2.61	1.57	6.50	0.37	2.76	0.374	0.525	8.26	5.00	240	354	16
2"	F07	2.95	1.96	7.00	0.37	2.76	0.374	0.525	8.26	6.00	400	424	21
2-1/2"	F07	3.52	2.55	7.50	0.66	2.76	0.669	1.140	10.23	7.00	700	585	38
3"	F10	4.23	3.14	8.00	0.66	4.02	0.669	1.140	10.23	7.50	980	982	46
4"	F10	4.84	3.93	9.00	0.66	4.02	0.669	1.140	12.20	9.00	1700	1239	73

**OPTIONAL ACCESSORIES INCLUDE:**  
**FUSIBLE LINK ASSEMBLIES • DEADMAN HANDLES • GEAR OPERATORS**

# MS-3PT 3 PIECE STAINLESS STEEL BALL VALVE

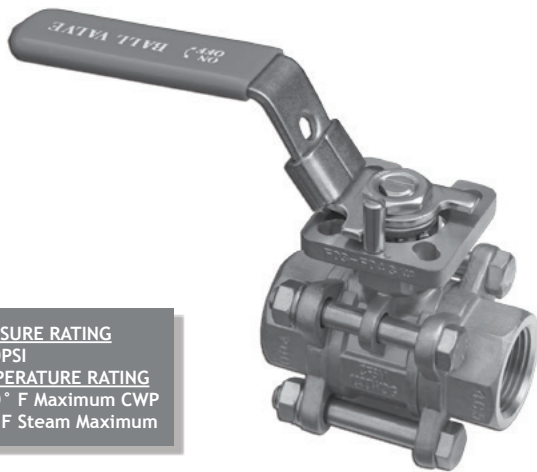

**PRESSURE RATING**  
1000PSI  
**TEMPERATURE RATING**  
+450° F Maximum CWP  
366° F Steam Maximum

## VALVE FEATURES

- Full port SS 3-piece valve
- 1/4" through 3"
- self-adjusting stem packing
- ideal for food and chemical applications
- swing-out 3-piece design for easy maintenance
- NPT, butt weld or socket weld
- ISO 5211 mounting pad for direct mount actuation

## BILL OF MATERIALS

PART #	NAME	MATERIAL	QTY
1	END CAP	ASTM A351 CF8M	2
2	BODY SEAL	TFE	2
3	BALL	ASTM A351 CF8M	1
4	BODY	ASTM A351 CF8M	1
5	SEAT	RTFE	2
6	WASHER	304SS	4
7	NUT	304SS	1
8	STEM SEAL	TFE	1
9	O-RING	VITON®	1
10	STEM PACKING	TFE	1
11	BELLEVILLE WASHER	304SS	2
12	STEM NUT	304SS	1
13	STEM	316SS	1

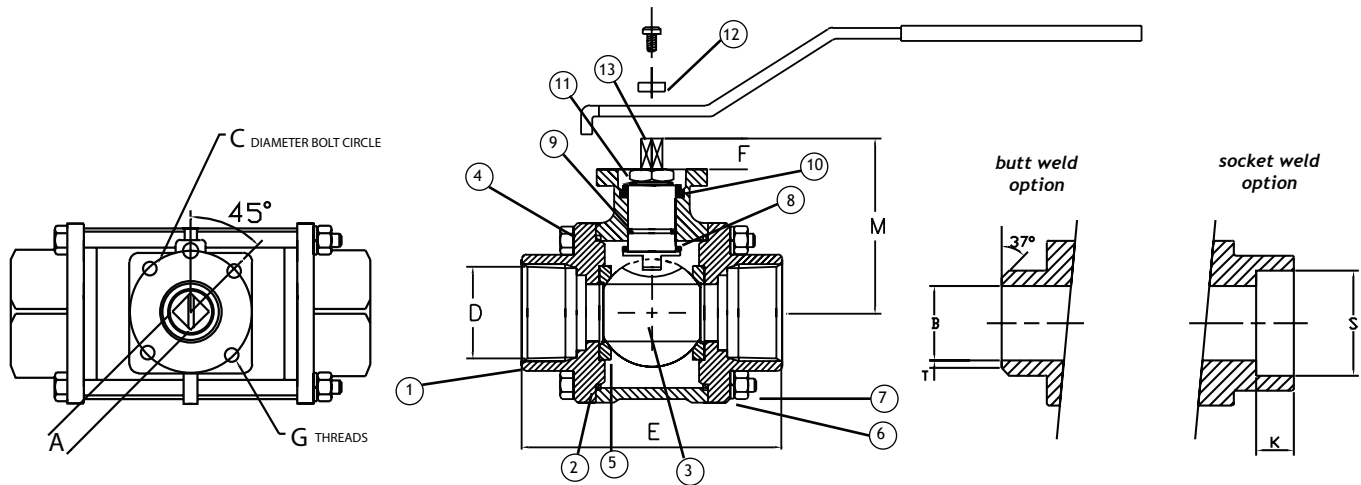

## DIMENSIONAL DATA

SIZE	ISO 5211	A	B	C	D	E	F	G	K	M	S	T	CV	PSI	WEIGHT (LBS.)
1/4"	F03-04	0.354	0.45	1.42/1.65	0.45	2.36	0.354	0.22/0.28	0.40	1.93	0.86	0.04	6	1000	1.27
3/8"	F03-04	0.354	0.50	1.42/1.65	0.50	2.36	0.354	0.22/0.28	0.40	1.93	0.86	0.04	9	1000	1.27
1/2"	F03-04	0.354	0.59	1.42/1.65	0.59	2.95	0.354	0.22/0.28	0.50	1.93	0.86	0.04	21	1000	1.45
3/4"	F03-04	0.354	0.79	1.42/1.65	0.79	3.15	0.354	0.22/0.28	0.62	2.09	1.06	0.04	37	1000	1.75
1"	F04-05	0.433	0.98	1.65/1.97	0.98	3.45	0.551	0.28/0.35	0.69	2.60	1.33	0.06	58	1000	3.10
1-1/4"	F04-05	0.433	1.26	1.65/1.97	1.26	4.33	0.551	0.28/0.35	0.75	2.83	1.67	0.06	93	1000	4.35
1-1/2"	F05-07	0.551	1.50	1.97/2.76	1.50	4.72	0.551	0.28/0.35	0.88	3.23	1.92	0.06	139	1000	6.65
2"	F05-07	0.551	1.97	1.97/2.76	1.97	5.51	0.551	0.28/0.35	0.88	3.63	2.41	0.09	232	1000	10.00
2-1/2"	F07-F10	0.669	2.50	2.76/4.02	2.50	6.54	0.790	0.28/0.35	0.88	4.41	2.91	0.10	371	800	21.30
3"	F07-10	0.669	3.14	2.76/4.02	3.14	7.40	0.790	0.35	1.00	4.81	3.54	0.10	557	800	30.00

**OPTIONAL ACCESSORIES INCLUDE:**  
**FUSIBLE LINK ASSEMBLIES • DEADMAN HANDLES • GEAR OPERATORS**

# MS-3W 3-WAY STAINLESS STEEL FULL PORT BALL VALVE

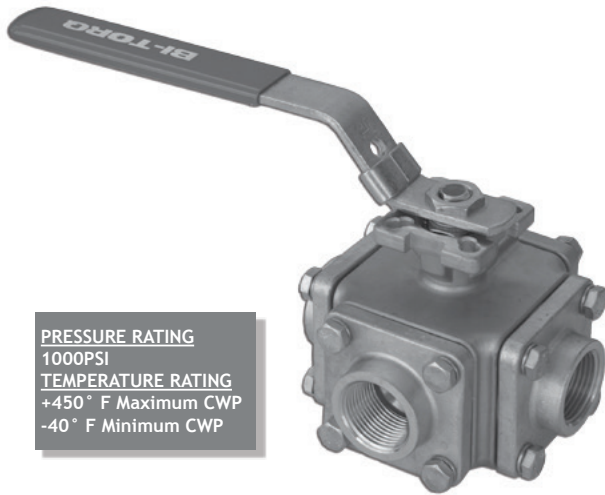

**PRESSURE RATING**  
1000PSI  
**TEMPERATURE RATING**  
+450° F Maximum CWP  
-40° F Minimum CWP

## VALVE FEATURES

- Full port, heavy duty construction multi-port ball valve
- 1/2" through 2"
- L-port and T-port
- 4-seat design for high cycle applications
- NPT or socket weld
- ISO 5211 mounting pad for direct mount actuation

## BILL OF MATERIALS

PART #	NAME	MATERIAL	QTY
1	BODY	316SS	1
2	END CONNECTION	316SS	3
3	BODY SEAL	PTFE	4
4	BALL	316SS	1
5	SEATS	RTFE	4
6	STEM	316SS	1
7	THRUST WASHER	PTFE	1
8	STEM PACKING	PTFE	1
9	GLAND	304SS	1
10	BELLEVILLE WASHER	304SS	2
11	PACKING NUT	304SS	1
12	SPRING WASHER	304SS	1
13	BODY BOLTS	304SS	1
14	BLANK CAP	316SS	1

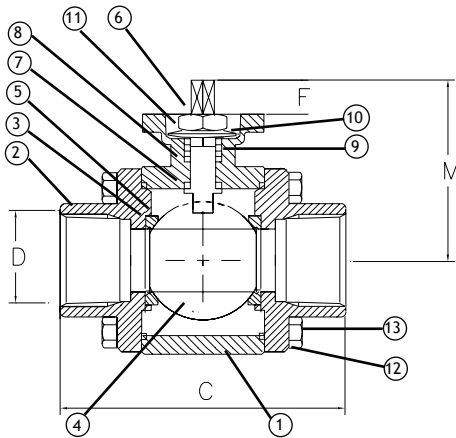

**NOTE: not suitable for vacuum service**

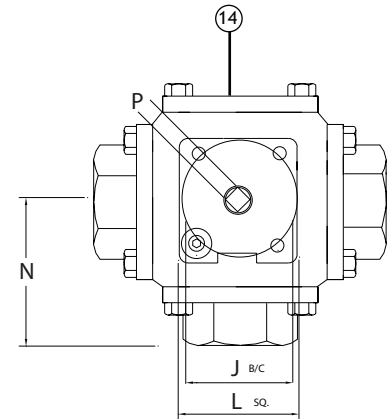

## DIMENSIONAL DATA

SIZE	ISO 5211	B	C	D	F	J	L	M	N	P	PSI	WEIGHT (LBS.)
1/2"	F03-04	3.50	3.78	0.50	0.30	1.42	1.65	2.26	1.89	0.354	1000	3.90
3/4"	F04-05	3.86	4.21	0.75	0.37	1.65	1.97	2.72	2.11	0.433	1000	5.65
1"	F04-05	4.02	4.96	1.00	0.43	1.65	1.97	2.93	2.48	0.433	1000	8.85
1-1/4"	F05-07	4.67	5.24	1.25	0.65	1.97	2.76	3.78	2.62	0.551	1000	11.90
1-1/2"	F05-07	5.00	5.94	1.50	0.67	1.97	2.76	4.07	2.97	0.551	1000	18.45
2"	F07-10	5.47	6.54	2.00	0.67	2.76	4.02	4.80	3.27	0.669	1000	23.25

**OPTIONAL ACCESSORIES INCLUDE:**  
**FUSIBLE LINK ASSEMBLIES • DEADMAN HANDLES • GEAR OPERATORS**

# FS-3PT FIRE-SAFE 3-PIECE HIGH-PERFORMANCE BALL VALVE



**PRESSURE RATING**  
2000 PSI (RTFE seats)  
**TEMPERATURE RATING**  
+450° F Maximum CWP  
-40° F Minimum CWP

## VALVE FEATURES

- Full port WCB/SS or all SS 3-piece ball valve
- ISO 5211 mounting pad for direct mount actuation
- API 607 Fire-Safe approved
- 1/4" through 2" sizes
- High-performance seat design
- Self-adjusting stem packing
- CRN, API and DIN certificates
- Swing-out 3-piece design for easy maintenance/repair
- NPT, butt weld or socket weld
- Female pipe threaded to NPT, DIN 259/2999, BS21 standards
- Inspection and testing to current API 598 standards
- Enclosed body bolt design for extreme service conditions

## BILL OF MATERIALS

PART #	NAME	MATERIAL (STANDARD)	MATERIAL (OPTIONAL)	QTY
1	BODY	CF8M	WCB	1
2	END CAP	CF8M	WCB	2
3	BALL	CF8M	--	1
4	SEAT	PTFE	RTFE, DELRIN, PEEK, OR TFM	2
5	BODY SEAL	GRAPHITE	PTFE	2
6	THRUST WASHER	GRAPHITE	PTFE	1
7	STEM PACKING	GRAPHITE	--	1
8	GLAND	304 SS	--	1
9	BELLEVILLE SPRING WASHER	301 SS	--	2
10	STEM	316 SS	304 SS	1
11	NUT	304 SS	--	1
12	SPRING WASHER	304 SS	--	1
13	NUT	304 SS	--	1
14	BOLT	304 SS	--	4
15	HANDLE	304 SS	ZINC PLATED STEEL	1
16	HANDLE SLEEVE	VINYL	--	1
17	SADDLE WASHER	304 SS	--	1
18	O-RING	VITON	--	1
19	STOP PIN	304 SS	--	1
20	ANTI-STATIC DEVICE	304 SS	--	1

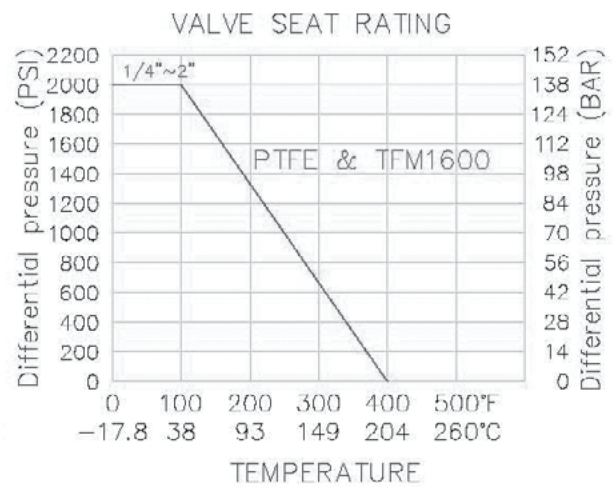
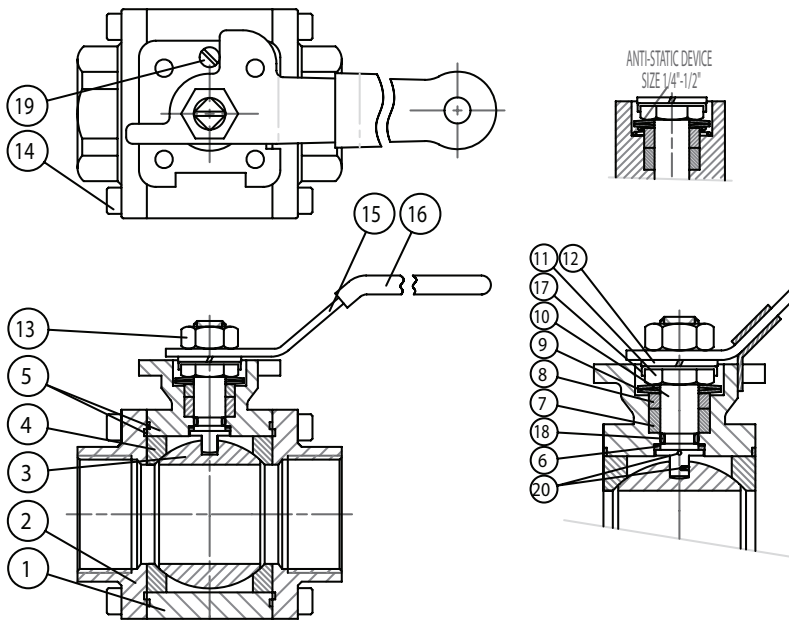

**OPTIONAL ACCESSORIES INCLUDE:**  
**FUSIBLE LINK ASSEMBLIES • DEADMAN HANDLES • GEAR OPERATORS**

# FS-3PT FIRE-SAFE 3-PIECE HIGH-PERFORMANCE BALL VALVE

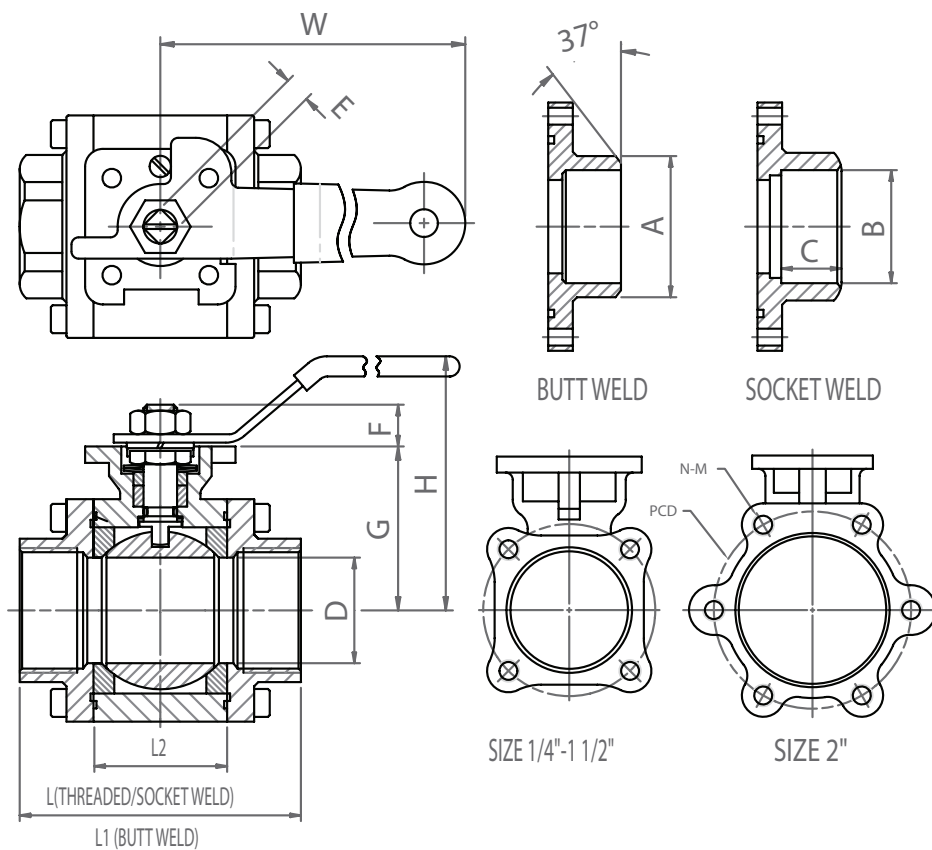

## DIMENSIONAL DATA

SIZE	ISO 5211	D	L	L1	W	H	E	F	G	A	B	C	TORQUE (IN LBS)*	CV	WEIGHT (LBS.)
1/4"	F04	0.433	2.559	2.756	5.512	2.559	0.354	0.315	1.476	0.543	0.559	0.394	55	8	2.42
3/8"	F04	0.433	2.559	2.756	5.512	2.559	0.354	0.315	1.476	0.681	0.693	0.394	55	8	2.42
1/2"	F04	0.551	2.953	2.953	5.512	2.953	0.354	0.315	1.476	0.854	0.858	0.512	65	40	2.42
3/4"	F04/F05	0.807	3.149	3.543	7.087	3.149	0.433	0.433	2.047	1.071	1.071	0.591	85	70	3.55
1"	F04/F05	0.984	3.543	3.937	7.087	3.543	0.433	0.433	2.362	1.339	1.335	0.591	135	110	4.85
1-1/4"	F07	1.240	4.331	4.331	8.464	4.409	0.551	0.669	2.835	1.681	1.681	0.591	195	230	7.36
1-1/2"	F07	1.457	4.724	4.921	8.464	4.528	0.551	0.669	2.992	1.913	1.913	0.630	240	340	10.13
2"	F07	1.968	5.512	5.906	8.464	5.236	0.551	0.669	3.661	2.382	2.409	0.669	405	595	16.10

\*with standard RTFE seats, 100 PSI clean service

VALVE SIZE	APPROX CV	EQUIVALENT LENGTH OF SCHEDULE 40 PIPE (FT.)	APPROXIMATE WEIGHT (LBS.)	TORQUE VALUE AT 100 PSI CLEAN SERVICE (RTFE SEATS)	TORQUE VALUE AT 100 PSI CLEAN SERVICE (DELIRIN SEATS)	TORQUE VALUE AT 100 PSI CLEAN SERVICE (PEEK SEATS)
1/2"	36	1.4	1.8	65	75	130
3/4"	71	1.0	3.0	85	98	170
1"	108	1.9	5.8	135	165	270
1-1/4"	230	2.1	6.4	195	255	390
1-1/2"	350	2.1	7.5	240	298	480
2"	600	2.1	29.1	405	500	810

**OPTIONAL ACCESSORIES INCLUDE:  
FUSIBLE LINK ASSEMBLIES • DEADMAN HANDLES • GEAR OPERATORS**

# MS-3WF 3-WAY FLANGED STAINLESS STEEL FULL PORT BALL VALVE

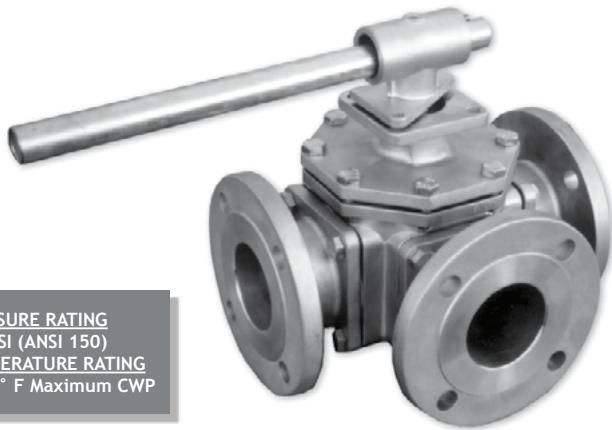

**PRESSURE RATING**  
275PSI (ANSI 150)  
**TEMPERATURE RATING**  
+450° F Maximum CWP

## VALVE FEATURES

- Maximum flow full port SS multi-port ball valve
- 1/2" through 4"
- ANSI Class 150# ends
- 4-seat design for high cycles
- ISO 5211 mounting pad for actuation
- Ideal for mixing applications

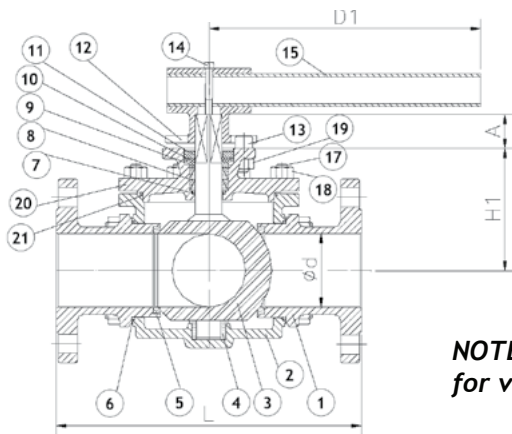

**NOTE: not suitable for vacuum service**

BILL OF MATERIALS			
PART #	NAME	MATERIAL	QTY
1	END CAP	CF8M	3
2	BODY	CF8M	1
3	BALL AND STEM	316SS	1
4	BUSHING	PTFE	1
5	SEATS	RTFE THROUGH 2" TFE 2-1/2" - 4"	4
6	BODY SEAL	TFE	4
7	O-RING	VITON®	1
8	STEM PACKING	TFE	1
9	PACKING GLAND	304SS	1
10	BELLEVILLE WASHER	304SS	2
11	GLAND NUT	304SS	1
12	HANDLE NUT	304SS	1
13	STOP PIN	304SS	1
14	HANDLE BOLT	304SS	1
15	HANDLE	304SS	1
16	BLIND CAP	CF8M	1
17, 18, 19	BOLTS AND NUTS	304SS	8
20	BONNET	CF8M	1
21	GASKET	TFE	1

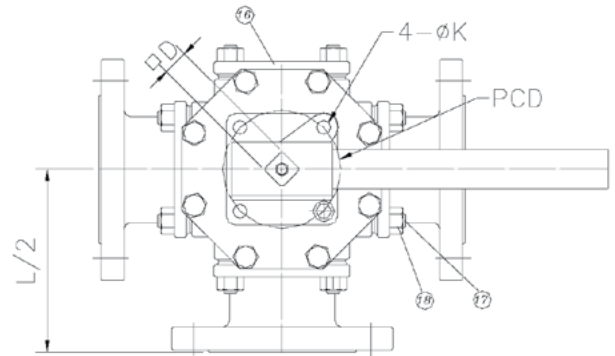

## DIMENSIONAL DATA

SIZE	ISO 5211	d	L	L/2	H1	A	D1	K	D	PSI	WEIGHT (LBS.)
1/2"	F03-04	0.50	5.98	2.99	2.26	0.30	5.71	0.24	0.354	275	8
3/4"	F04-05	0.75	6.57	3.29	2.72	0.37	6.50	0.24	0.433	275	10
1"	F04-05	1.00	7.28	3.64	2.93	0.43	7.68	0.31	0.433	275	15
1-1/4"	F05-07	1.25	7.97	3.98	3.78	0.61	8.12	0.31	0.551	275	22
1-1/2"	F05-07	1.50	8.66	4.33	4.07	0.65	9.84	0.39	0.551	275	29
2"	F07-10	2.00	9.96	4.98	4.78	0.67	12.20	0.39	0.669	275	48
2-1/2"	F10	2.44	11.81	5.91	6.16	0.98	19.69	0.43	0.866	275	55
3"	F10	2.99	12.01	6.00	5.37	0.98	25.59	0.43	0.866	275	71
4"	F10	3.78	14.51	7.25	6.16	0.98	25.59	0.43	0.866	275	118

**OPTIONAL ACCESSORIES INCLUDE:**  
**FUSIBLE LINK ASSEMBLIES • DEADMAN HANDLES • GEAR OPERATORS**

# MC-3W OR MV-3W 3-WAY PVC OR CPVC BALL VALVE

**PRESSURE RATING**  
235PSI at 73° through  
2" for standard valve  
**TEMPERATURE RATING**  
varies with o-ring  
material (EPDM, Viton®,  
BUNA-N)



## VALVE FEATURES

- Heavy-duty PVC ball valve
- 1/2" through 2"
- threaded, socket or flanged ends
- 4-seat design for high cycle applications
- ISO 5211 mounting pad for direct actuation

## BILL OF MATERIALS

PART #	NAME	MATERIAL	QTY
1	INSERT TOOL	PVC	1
2	HANDLE	PVC	1
3	STEM O-RING	EPDM, BUNA-N OR VITON®	1
4	STEM	PVC	1
5	BALL SEAT	PTFE	4
6	BALL	PVC	1
7	BODY	PVC	1
8	BACKING O-RING	EPDM, BUNA-N OR VITON®	4
9	BODY O-RING	EPDM, BUNA-N OR VITON®	3
10	SOCKET O-RING	EPDM, BUNA-N OR VITON®	3
11	BALL SEAT SUPPORT	PVC	3
12	END CONNECTOR	PVC	3
13	UNION NUT	PVC	3
14	BLOCKING BUTTON	POM	1
15	STOP RING	PVC	3

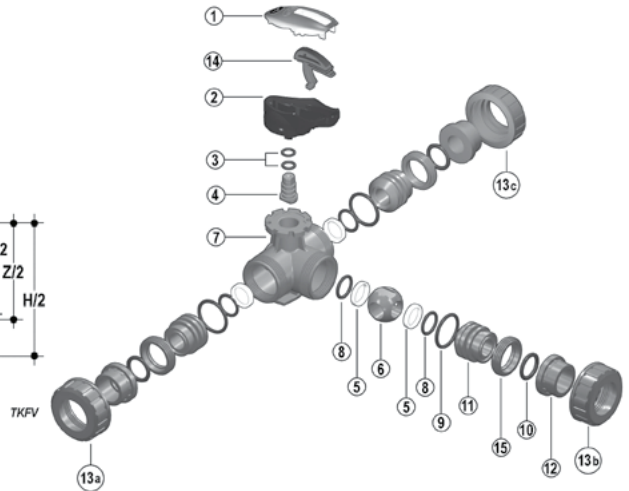
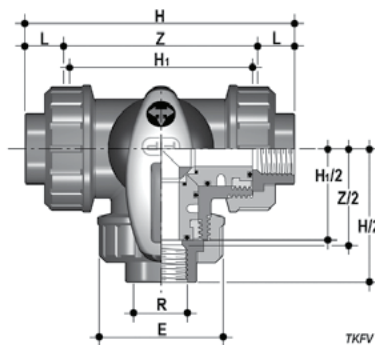
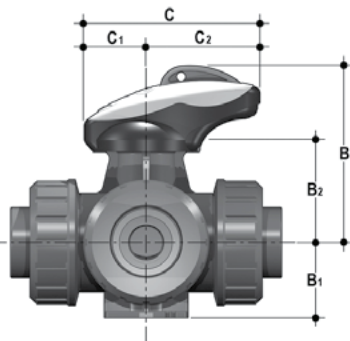

## DIMENSIONAL DATA

SIZE	ISO 5211	B	B1	B2	C	C1	C2	d	E	H	H1	L	R	Z	WEIGHT (LBS.)
1/2"	F04	3.44	1.30	1.97	3.29	1.16	2.13	0.84	2.17	5.20	3.15	0.91	0.50	3.56	0.77
3/4"	F05	3.88	1.54	2.22	3.86	1.40	2.46	1.05	2.60	6.27	3.94	1.00	0.75	4.26	1.32
1"	F05	4.17	1.77	2.42	4.13	1.46	2.68	1.32	2.95	6.85	4.33	1.13	1.00	4.59	1.87
1-1/4"	F07	5.31	2.01	3.01	5.49	2.01	3.48	1.66	3.43	8.07	5.16	1.66	1.25	5.55	2.98
1-1/2"	F07	5.47	2.24	3.17	5.49	2.01	3.48	1.90	3.94	8.96	5.83	1.38	1.50	6.20	3.86
2"	F07	6.26	2.72	3.84	6.06	2.01	4.06	2.38	4.80	10.51	7.05	1.38	2.00	7.66	6.50

**OPTIONAL ACCESSORIES INCLUDE:**  
**FUSIBLE LINK ASSEMBLIES • DEADMAN HANDLES • GEAR OPERATORS**

# MC-3PS OR MV-3PS 3-PIECE PVC OR CPVC BALL VALVE

**PRESSURE RATING**  
235PSI at 73° through  
2" for standard valve  
**TEMPERATURE RATING**  
varies with o-ring  
material (EPDM, Viton®,  
BUNA-N)



## VALVE FEATURES

- PVC, CPVC, PVDF or Polypropylene construction
- 1/2" through 6"\*
- TFE seats and EPDM, BUNA-N or Viton® o-ring seals
- Threaded, socket or flanged
- Patented design to help prevent leakage in case of stem damage
- ISO 5211 mounting pad saddles for easy actuation retrofit

**\*NOTE: 5" and 6" valves are venturied style on a 4" body**

**Valves are available in PVC, CPVC, PVDF or Polypropylene Construction**

**Please consult factory for media compatibility**

## BILL OF MATERIALS

PART #	NAME	MATERIAL	OPTION	QTY
1	STEM	PVC	CPVC	1
2	STEM O-RING	EPDM	BUNA-N VITON®	1
3	STEM BEARING	PP (1-1/4"*)	---	1
4	UNION NUT	PVC	CPVC	2
5	SEAT	TFE	---	2
6	BALL	PVC	CPVC	1
7	BODY	PVC	CPVC	1
8	CARRIER O-RING	EPDM	BUNA-N VITON®	1
9	SEAL CARRIER	EPDM	BUNA-N VITON®	1
10	END CONNECTOR	PVC	CPVC	2
11	CONNECTOR O-RING	EPDM	BUNA-N VITON®	2

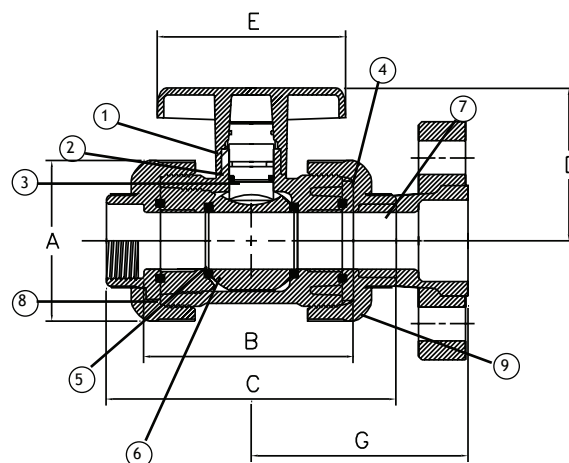

## DIMENSIONAL DATA

SIZE	A	B	C	D	E	G	CV	PSI	WEIGHT (LBS.)
1/2"	2.56	3.44	5.19	2.41	2.72	3.46	25	235	1.05
3/4"	3.03	4.03	6.19	2.63	3.19	4.00	51	235	1.44
1"	3.41	4.31	6.56	2.81	3.72	4.31	97	235	1.91
1-1/4"	3.69	4.50	7.03	2.97	4.13	4.59	204	235	2.38
1-1/2"	4.38	5.31	8.03	3.28	4.47	5.28	285	235	3.63
2"	5.19	5.81	8.81	4.40	5.25	5.72	540	235	5.40
2-1/2"	7.44	8.19	11.88	4.91	9.88	7.18	712	150	12.87
3"	7.44	8.38	11.94	4.91	9.88	7.34	1294	150	13.24
4"	8.94	8.69	13.18	5.59	10.81	8.16	2629	150	19.58

**OPTIONAL ACCESSORIES INCLUDE:  
FUSIBLE LINK ASSEMBLIES • DEADMAN HANDLES • GEAR OPERATORS**

# MY SERIES BUTTERFLY VALVES

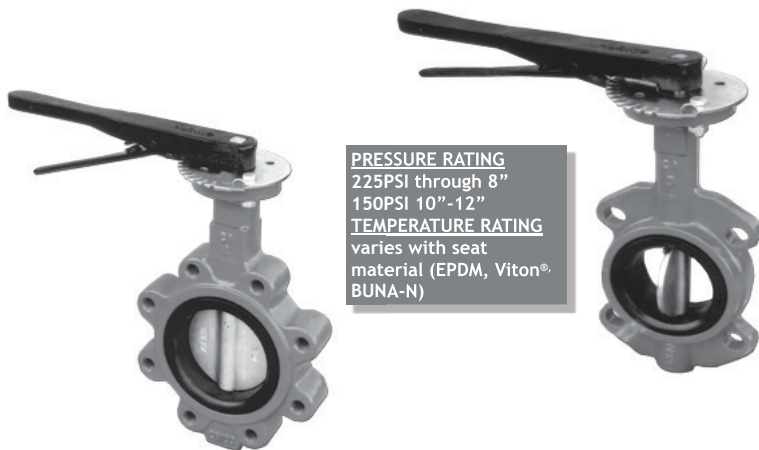

**PRESSURE RATING**  
225PSI through 8"  
150PSI 10"-12"  
**TEMPERATURE RATING**  
varies with seat  
material (EPDM, Viton®,  
BUNA-N)

## BILL OF MATERIALS

DESCRIPTION	MATERIAL	QTY
BODY	CAST IRON	1
BOTTOM BUSHING	BRONZE	1
SHAFT	316SS	1
SEAT	EPDM, BUNA OR VITON®	1
DISC	316SS	1
TAPER PINS	316SS	1-2
NAME PLATE	316SS	1
RIVETS	316SS	2
TOP BUSHING	BRONZE	1
O-RING	EPDM	1

## VALVE FEATURES

- wafer or lug style 2" through 12"
- **STANDARD** stainless steel disc and shaft on all sizes
- ISO direct mount for easy automation retrofit
- standard 10-position locking handle on all valves
- cast iron, aluminum and stainless steel gears available
- additional sizes through 24" also available

## 10 POSITION HANDLE

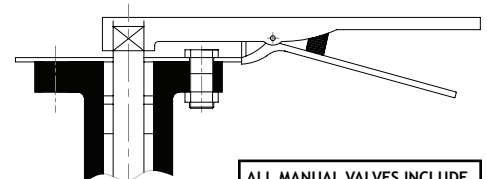

ALL MANUAL VALVES INCLUDE STANDARD 10-POSITION LOCK-IN-PLACE HANDLE

CAST IRON, ALUMINUM AND SS GEAR OPERATORS ALSO AVAILABLE

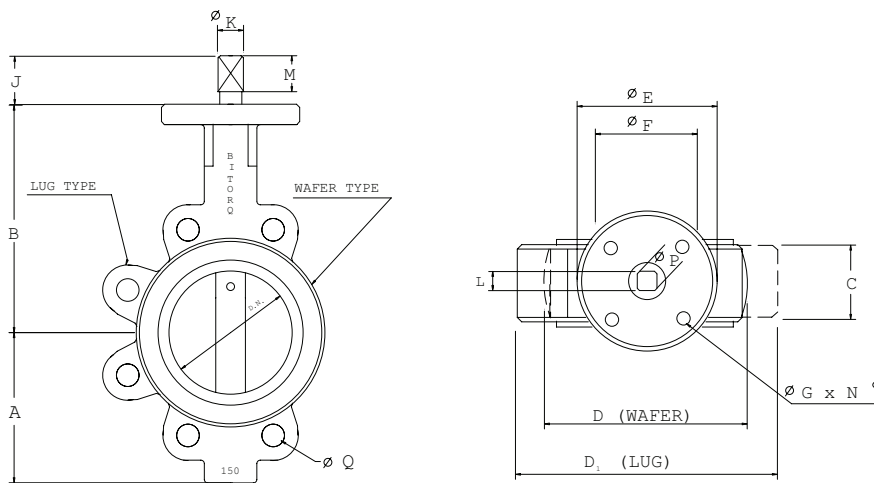

## DIMENSIONAL DATA

SIZE	ISO 5211	A	B	C	D (WAFFER)	D (LUG)	E	F	G X NO.	J	K	L	M	Q	WEIGHT (WAFFER)	WEIGHT (LUG)
2"	F07	3.15	6.34	1.69	4.02	5.98	3.54	2.76	0.354 x 4	1.023	0.551	0.433	0.669	0.687	6	7
2-1/2"	F07	3.50	6.89	1.81	4.76	6.74	3.54	2.76	0.354 x 4	1.023	0.551	0.433	0.669	0.687	7	8
3"	F07	3.74	7.13	1.81	5.47	7.87	3.54	2.76	0.354 x 4	1.023	0.551	0.433	0.669	0.687	10	14
4"	F07	4.49	7.87	2.05	6.30	9.02	3.54	2.76	0.354 x 4	1.181	0.709	0.551	0.826	0.687	13	26
5"	F07	5.00	8.39	2.20	7.48	10.00	3.54	2.76	0.354 x 4	1.181	0.709	0.551	0.826	0.812	18	28
6"	F07	5.47	8.90	2.20	8.46	11.02	3.54	2.76	0.354 x 4	1.299	0.866	0.669	0.945	0.812	20	31
8"	F07	6.89	10.24	2.36	10.59	13.50	3.54	2.76	0.472 x 4	1.299	0.866	0.669	0.945	0.812	32	49
10"	F10	7.99	11.50	2.68	13.11	15.98	4.92	4.02	0.472 x 4	1.850	1.102	0.866	0.945	0.937	42	72
12"	F10	9.53	13.27	3.07	15.08	19.02	4.92	4.02	0.472 x 4	1.850	1.102	0.866	0.945	0.937	70	105

**OPTIONAL ACCESSORIES INCLUDE:**  
**FUSIBLE LINK ASSEMBLIES • DEADMAN HANDLES • GEAR OPERATORS**

## THE STRAHMAN FAMILY OF PRODUCTS INCLUDE:



### WASH DOWN EQUIPMENT

Cleaning and sanitizing equipment for applications where safety is the number one concern — built to outlast and outperform all others.

### AUTOMATED VALVES & THERMAL SHUT-OFF VALVES

Completely assembled automated valves and fire-safe thermal shut-off valves fabricated for quick and reliable problem-solving solutions for industrial applications.

### PROCESS VALVES

Engineered solutions for the transfer of fluid and flow control for highly critical applications from sampling to inline process to permanent isolation.





© STRAHMAN GROUP | PUBLISHED 11.01.25

## CONTACT US

Need more information? Give us a call today or visit our website.

 877-787-2462

 2801 Bagylos Circle  
Bethlehem, PA 18020

 [StrahmanGroup.com](http://StrahmanGroup.com)



PRECISION AND PERFORMANCE

an fch business