

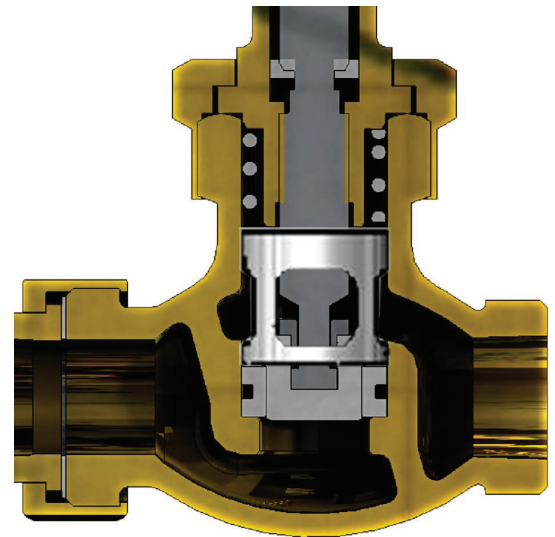

SOFT-SEAL PISTON GLOBE VALVE

INSTALLATION OF THE SOFT SEAL PISTON CONVERSION KIT

1. Loosen body nut #11 and remove entire stem assembly from body #1.
2. Remove old valve ring #3 and base ring #2 from valve body #1 using puller. Blow out all foreign matter inside of valve body.
3. Remove handwheel #16, nut #17, 1" washer #18, ident. tag #19, packing nut #15 and bonnet nut #11 from old valve body. Set these parts aside for reuse on conversion.
4. Place valve ring #3 on seating tool and drive into valve body as far as it will go. Keep seater tool straight as possible when inserting ring.
5. Install lantern #8 with larger dia. and wider section of band facing up. Make sure lantern sits evenly on ring.
6. Reassemble bonnet nut #11, gland #14, packing nut #15, handwheel #16 and parts #17, #18 and #19 to conversion kit assy. Tighten packing nut #15 lightly.
7. Before installing bonnet conversion assembly into valve body, fully retract stem. Install into body. Tighten down bonnet nut #11 to refusal. Base ring no longer necessary (older valves only).



PARTS			
PART NO.	PART	PART NO.	PART
1	BODY SCREWED ENDS	12	RETAINING RING (set of 6)
1	BODY SCREWED ENDS SS	13	PACKING RING
1	BODY UNION TYPE	14	PACKING GLAND
3	VALVE RING	15	PACKING NUT
4	PISTON	15	PACKING NUT SS 303
5	SPLITNUT	16	BLACK HANDWHEEL
6	STEM (includes part 7)	16	RED HANDWHEEL
7	STEM STOP (set of 6)	17	HANDWHEEL NUT (set of 6)
8	LANTERN	20	UNION GASKET (set of 6)
9	SPRING	20	SPIRAL WOUND GASKET Graphite
10	BONNET Bronze	21	UNION TAIL PIECE
10	BONNET SS 303	21	UNION INLET NUT
11	BONNET NUT	23	ANGLE RECESSED GASKET
11	BONNET NUT SS 303		

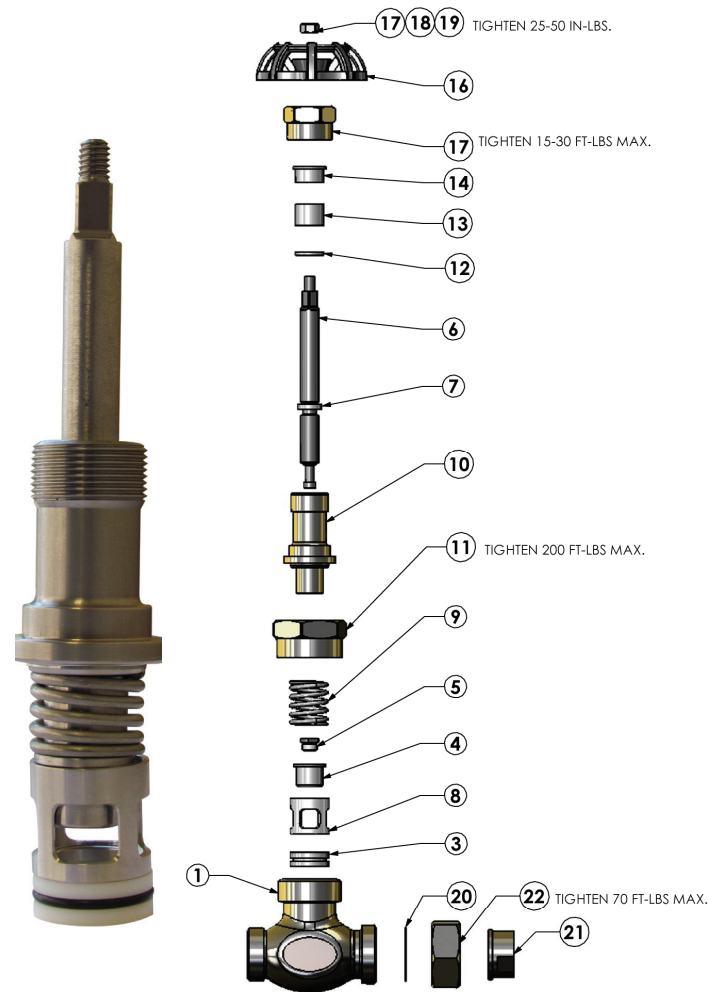

Maximum: Pressure 150 psi, Temperature 370°F