



SAMPLING VALVES





LIVE SAMPLE EXTRACTION CONTAINERS

Strahman Sample Valves enable facility operators to extract live samples from their systems during the manufacturing process. In addition, placing valves at multiple areas throughout the line will allow the operator to promptly take corrective action in the process line, thereby improving quality assurance.

Since operator safety is the utmost concern, Strahman recommends using an adequate sample storage device with our sample valves. Strahman offers a complete line of sample storage accessories designed to effectively isolate a sample while protecting the operator from accidental exposure. Strahman has shown proven industry-leading solutions for safe and reliable sample extractions for over 100 years.



Strahman's standard Sample Valve SV Series, with its non-clogging design, will safely and reliably draw live samples. Our Sample Valves, used in conjunction with our extraction containers, will further reduce any dangerous risk to the operator.

-  Safe and reliable extraction
-  Reduces risk of dangerous spills, splashes, and overages
-  Provides maximum protection for the operator
-  Customizable to your required thread-type specifications



SVBA
BOTTLE ADAPTER

- Polycarbonate protective shield
- GL45 Threaded Glass, 250ML or 500ML (customer may also supply their own)
- Glass Bottle maximum temperature to 400°F / 100 Kelvin Thermal Shock rating
- Flanged or threaded adapter per customer specs
- 1/8" x 1/4" NPT vent



SVBLA
LOCKING BOTTLE ADAPTER

- Outer shield of solid SS316 construction, inner liner of glass for added level of protection
- GL45 Threaded Glass, 250ML or 500ML (customer may also supply their own)
- Glass Bottle maximum temperature to 400°F / 100 Kelvin Thermal Shock rating
- 1/8" x 1/4" NPT vent



SVBC
BOX CONTAINER

- Heavy-duty brushed aluminum 316L or 6061 (other materials available upon request)
- 6-1/2" w x 7-1/4" d x 15-1/4" h (custom sizes upon request)
- Locking hinge for added security
- Glass window for viewing; add your own container to receive the sample

Sample Valve Box Container

SVBC

Products Range

Size: 6.8125"W x 8.8125"D x 18.4375"H

Design Features

- Heavy-Duty 316L or 6061
- Brushed aluminum
- Secure locking mechanism
- Glass window for better visibility to monitor sample extraction

Applications

Valves in liquid pipelines

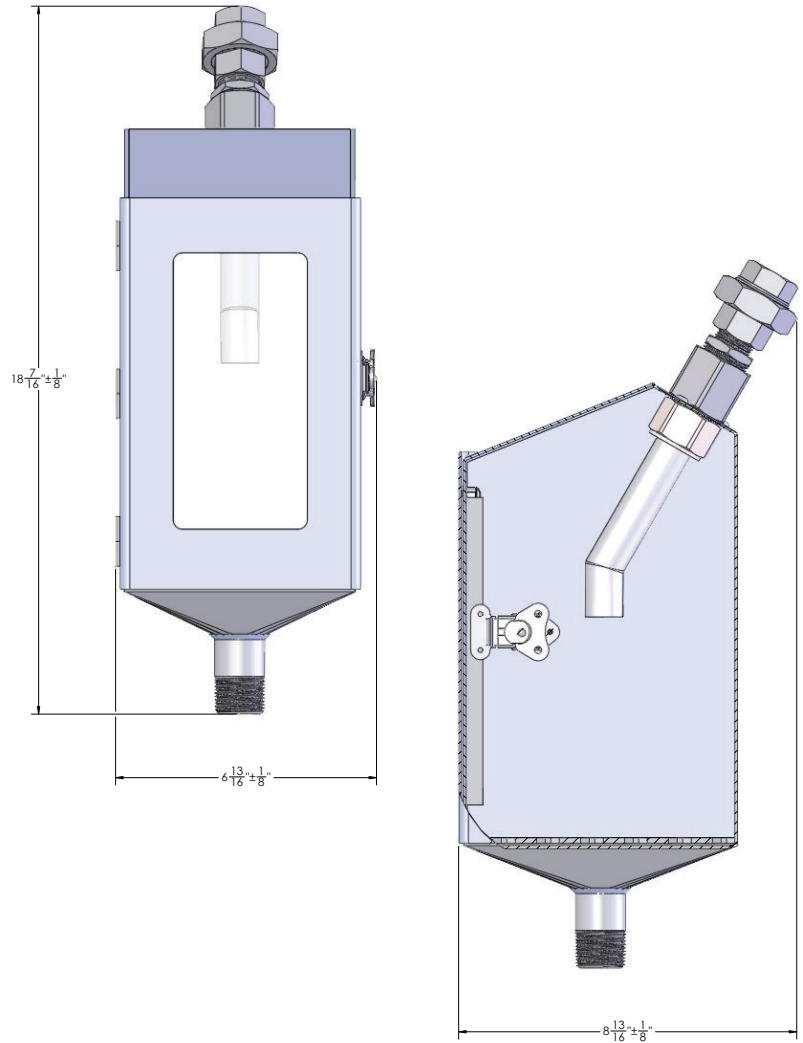

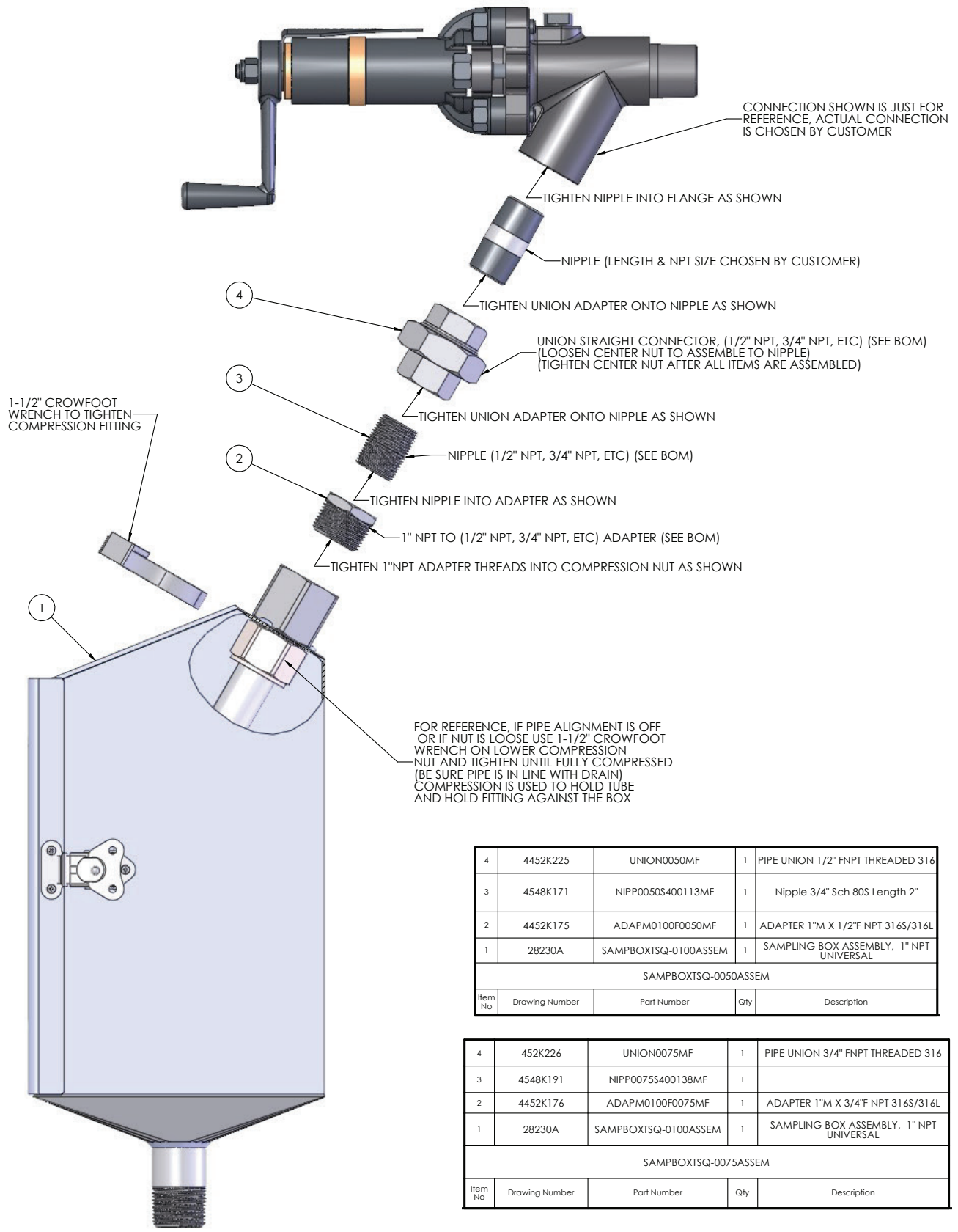

4	4452K225	UNION0050MF	1	PIPE UNION 1/2" FNPT THREADED 316
3	4548K171	NIPP0050S400113MF	1	Nipple 3/4" Sch 80S Length 2"
2	4452K175	ADAPM0100F0050MF	1	ADAPTER 1" M X 1/2" F NPT 316S/316L
1	28230A	SAMPBOXTSQ-0100ASSEM	1	SAMPLING BOX ASSEMBLY, 1" NPT UNIVERSAL
SAMPBOXTSQ-0050ASSEM				
Item No	Drawing Number	Part Number	Qty	Description

4	452K226	UNION0075MF	1	PIPE UNION 3/4" FNPT THREADED 316
3	4548K191	NIPP0075S400138MF	1	
2	4452K176	ADAPM0100F0075MF	1	ADAPTER 1" M X 3/4" F NPT 316S/316L
1	28230A	SAMPBOXTSQ-0100ASSEM	1	SAMPLING BOX ASSEMBLY, 1" NPT UNIVERSAL
SAMPBOXTSQ-0075ASSEM				
Item No	Drawing Number	Part Number	Qty	Description