



HR-100

Durable Stainless Steel Hose Storage

The Strahman HR-100 Hose Rack combines sleek design with rugged performance. Built from heavy-gauge stainless steel, it provides a reliable and visually appealing solution for storing hoses in any industrial setting.

Keep hoses neatly coiled and off the floor to maintain cleanliness, reduce wear, and prevent tripping hazards. This wall-mounted hose rack is ideal for areas where a water mixing hose station is not required but organized hose storage is essential.

KEY FEATURES

- **Heavy-duty:** Stainless Steel construction for long-lasting durability
- **Wall-mounted:** keeps hoses elevated and work areas clean
- **Easy installation:** on standard masonry surfaces such as brick, tile, cement, or cinder block
- **Mounting hardware:** expanded metal anchors included

DESIGN SPECS	
MODEL	DESCRIPTION
HR-100	Will hold up to 50' of hose
HR-100L	Will hold up to 100' of hose



Show with a Strahman Premium Washdown Hose and M-70 Washdown Spray Nozzle. Hose and nozzle are sold separately.

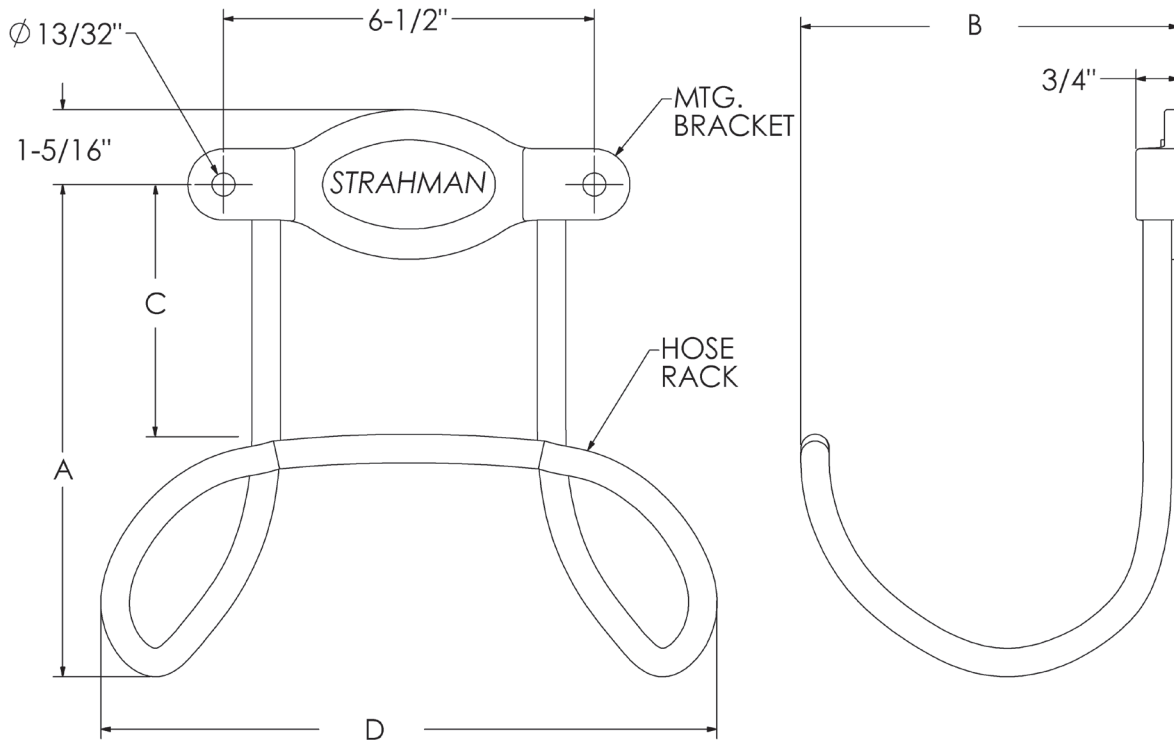

SPECIFICATIONS					
MODEL	CAPACITY	A	B	C	D
HR100MK	Up to 50' of hose	9.125"	6.5"	5"	10.5"
HR100MK60	Up to 100' of hose	13.5"	9.375"	7.5"	12"

Installation

1. Using 5/8" Masonry Drill, drill two holes on a horizontal line made deep enough to admit the Loxin Shields.
2. Insert Shields with nut end to back of hole.
3. Tighten screw until rack is securely fastened to wall.

