



HYDRO-PRO 150® WATER SAVER NOZZLE

INSTRUCTIONS FOR SERVICING SPRAY NOZZLE

If the Hydro-Pro 150 begins to leak from the seat (14) or rear of the body (1) follow the steps below. For best results, order original Strahman parts.

1. Disassemble the renewable cover (2) by loosening and removing the six cover screws (4) (not shown).
2. Lift the body (1) free of the cover (2). Remove the ratchet assembly hinge (3), ratchet (5), and ratchet spring pin (13). Place the body in boiling water for 2-3 minutes to release the Loc-Tite bond on stem screw (11). Remove the stem screw (11) and swivel the U-bracket (17) down or up away from the stem (9).
3. Remove the snap rings (7) from the front and rear of the water saver body (1). Push on the rear of the stem (9) until the seat stem (14) and stem spring (10) are free of the body.
4. Carefully press the housing (8) out of the rear of the water saver body (1). Precautions should be taken to avoid damaging the inside of the water saver body.
5. Install a new "O-ring" (6) on the seat (14). Install a new "O-ring" (6) on the new housing (8).
6. Install seat (14) and snap-ring (7) in the front of the water saver body (1). Install the stem (9) and then stem spring (10) from the rear of the water saver body.
7. Install the housing (8) in the rear of the body and compress the stem spring (10). Install a snap ring (7) in the rear of the water saver body.
8. Swivel the U-bracket (17) back into place over the end of the stem (9). Apply Loc-Tite 271 to the stem screw (12) and reinstall.
9. Re-install the body (1) and ratchet assembly-hinge (3) ratchet (5), and ratchet spring pin (13) in the new renewable cover (2). Reinstall the six cover screws (4) (not shown)



RENEWABLE COVER - BLACK

RENEWABLE COVER - WHITE

RENEWABLE COVER - RED

RENEWABLE COVER REPLACEMENT

If the renewable cover (2) becomes worn or cracked, follow the steps below to replace it.

1. Disassemble the renewable cover (2) by loosening and removing the six cover screws (4) (not shown).
2. Lift the body (1) free of the cover (2). Remove the ratchet assembly hinge (3), ratchet (5), and ratchet spring pin (13).
3. Install the body (1) and ratchet assembly-hinge (3) ratchet (5), ratchet spring (13) and spring pin (14) in the new renewable cover (2). Reinstall the six cover screws (4) (not shown)

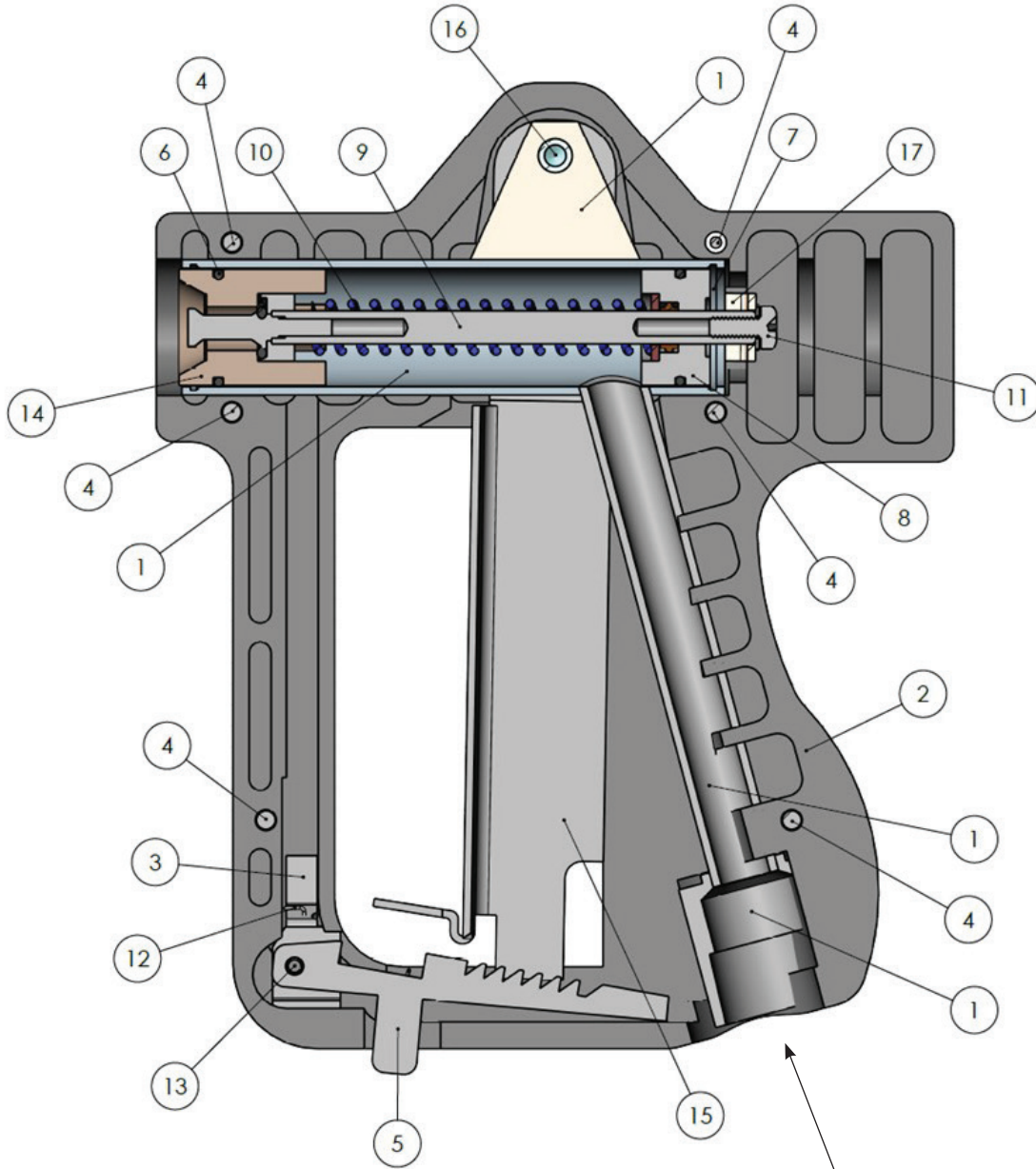

PARTS LIST		
ITEM NO.	ORDER NUMBER	DESCRIPTION
1	HPBODYASSM	HYDRO-PRO 150® BODY
2	WSHP1COVER0007	RENEWABLE COVER - BLACK
	WSHP1COVER0008	RENEWABLE COVER - RED
	WSHP1COVER0009	RENEWABLE COVER - WHITE
3*	HP1HINGESS	RATCHET HINGE, SST
4	HP1SCR	COVER SCREWS (SET OF 6) (NOT SHOWN)
5	HP150RACHETASSY	RATCHET ASSEMBLY (INCLUDES ITEMS #3, 12, 13)
6	ORNG18MMO2MMEA	O-RINGS (SET OF 6)
7	HP1SNAPRINGSS	SNAP RETAINING RING, SST
8	HP1HOUSASSY	HOUSING, SST
9	HP150STEMASSY	STEM ASSEMBLY
10	SPRG12339S3SS	STEM SPRING (SET OF 6), SST
11	MSN8320038LWOZ	STEM SCREW & WASHER (SET OF 6)
12*	SPRG12410S5SS	RATCHET SPRING, SST
13*	HP1SPINSS	RATCHET SPRING PIN (SET OF 6) SST
14	HP1SEAT	HP 150 SEAT, SST
	HP1SEATLFSS	HP 150 LOW FLOW SEAT, SST
15	HP1LARM	LEVER ARM
16	WSHP1LPIVO000	LEVER ARM PIVOT ASSY
17	HP1UBRKSS	U-BRACKET, SST

* IS ALSO A PART OF A COMPLETE ASSEMBLY ITEM #5

**Add pipe sealant at this connection;
tighten to ensure an adequate seal.**