



# INSTALLATION AND MAINTENANCE MANUAL FOR FIRE SAFE BALL VALVES

## INTRODUCTION

The BI-TORQ InstruPak FS/FW-3PT series uses the FS or FW-3PT NPT or socket weld fire safe ball valve. The 3-piece body design provides easy replacement of gaskets, seals and seats without any special tools. The floating ball design allows the ball to move horizontally in the ball cavity with line pressure, creating a bubble-tight shut-off and allowing the valve to be used in either flow direction or for dead-end service.

## 1. USE

1.1 The life of the valve can be maximized if valve use is within the stated pressure, temperature and corrosion ranges.

## 2. MANUAL OPERATION

2.1 Valve in open position: handle is parallel (in-line) with the valve or pipeline.

2.2 Valve in closed position: handle is perpendicular (crossed) to the valve or pipeline.

## 3. AUTOMATED OPERATION

3.1 Valves with actuators should be checked for stem alignment. Most ISO mount electric and pneumatic actuators are direct mount to the FS/FW-3PT ball valve. A mounting kit is required for use with fusible link assemblies. Make sure that all drive couplers or inserts are properly placed on the valve stem and fully engaged in the actuator before automating.

## 4. GENERAL INFORMATION FOR ON-SITE INSTALLATION

4.1 The valve may be fitted in any position in the pipeline. For automated operation, BI-TORQ does recommend that the valve and actuator be installed vertically in case of valve leakage, although this is not necessary for proper operation of the valve.

4.2 To prevent damage to the seats and ball surface, the pipeline must be flushed so that it is free of dirt, burrs and welding residues before installing the valve.

## 5. INSTALLATION OF THREADED VALVES

5.1 Use a conventional thread sealant such as hemp core, TFE, etc.

5.2 Apply the wrench on the hexagon end of the valve only. **CAUTION:** Tightening in the pipeline by using the valve body of handle can seriously damage the valve.

5.3 For applications where screwed end valves are back-welded on site, the valves must be dismantled according to the instructions for weld end valves.

## 6. INSTALLATION OF SOCKET WELD VALVES

**NOTE 1:** If the valve being welded into place has an electric or pneumatic actuator, remove the actuator before proceeding.

All “soft parts” (seats, seals, gaskets) must be removed before welding. See CHART 1.1 FOR COMPLETE PARTS BREAKDOWN

**NOTE 2: IMPORTANT:** Graphite gaskets and TFE/RTFE seats must be replaced with new seats and seals before reassembly.

6.1 Tack-weld the valve on the pipe in four points on both end caps.

6.2 With the valve in the open position (with the lever or actuator parallel to the axis of the pipe), remove all body bolts.

6.3 Turn the handle or valve stem to the half-open position to assist in the removal of the seats and gaskets.

6.4 Turn the handle or valve stem to the closed position and remove the ball.

6.5 Place all the removed parts in a clean and secure area.

6.6 Finish welding both end caps onto the pipe.

6.7 After the pipeline and the valve ends cool, clean the end caps.

6.7 Replace the body and the removed bolts onto the valve ends. Tighten all nuts by hand. **DO NOT OVERTIGHTEN.** Follow torque values in Table 1. To prevent any leakage to the body joints after welding, make sure that the body and the end caps remain perfectly parallel.

# INSTALLATION AND MAINTENANCE MANUAL FOR 2-WAY FLANGED BALL VALVES

## 7. DISSASSEMBLING AND CLEANING THE VALVE

**NOTE:** If the valve being socket welded into place has an electric or pneumatic actuator, remove the actuator before proceeding.

**CAUTION:** Ball valves can trap fluids in the ball cavity when it is in the closed position. If the valve has been used with hazardous media, it must be decontaminated before disassembly or handling.

**WARNING:** All persons involved in the removal or disassembly of the valve should wear protective gear such as eye and face protection, gloves, etc.

7.1 Relieve the line pressure.

7.2 Place the valve in the half-open position and flush the line to remove any hazardous material(s) from the valve.

## 8. REPLACING THE THRUST WASHER, PACKING AND SEATS

**NOTE:** The IS-3PT series valve is designed with belleville washers for automatic wear compensation. If there are signs of leakage from the stem, it is time to replace the stem packing and thrust washer.

**NOTE:** If the valve being socket welded into place has an electric or pneumatic actuator, remove the actuator before proceeding.

8.1 Before replacing the thrust washer and the packing, the pipeline must be depressurized.

8.2 Maintenance, removal and replacement of seats and seals is simple even if the valve is installed in line. By removing the body bolts, the valve center section can be removed from the line (SEE ILLUSTRATION 1.1). Seats, seals, gaskets and balls can be replaced without disturbing the pipe alignment.

## 9. BOLT TIGHTENING SPECIFICATIONS

The body bolts on the valve must be tightened evenly. Tighten the bolts by hand, then use a wrench to tighten bolts in diagonal opposition. If possible, test valve before placing back into line. If not properly secured, the valve can separate from the pressure source, resulting in potential injury.

**CHART 1.1:  
Bill of Materials**

PART #	NAME	MATERIAL (STANDARD)	MATERIAL (OPTIONAL)	QTY
1	BODY	CF8M	WCB	1
2	END CAP	CF8M	WCB	2
3	BALL	CF8M	--	1
4	SEAT	PTFE	RTFE, DELRIN, PEEK, OR TFM	2
5	BODY SEAL	GRAPHITE	PTFE	2
6	THRUST WASHER	GRAPHITE	PTFE	1
7	STEM PACKING	GRAPHITE	--	1
8	GLAND	304 SS	--	1
9	BELLEVILLE SPRING WASHER	301 SS	--	2
10	STEM	316 SS	304 SS	1
11	NUT	304 SS	--	1
12	SPRING WASHER	304 SS	--	1
13	NUT	304 SS	--	1
14	BOLT	304 SS	--	4
15	HANDLE	304 SS	ZINC PLATED STEEL	1
16	HANDLE SLEEVE	VINYL	--	1
17	SADDLE WASHER	304 SS	--	1
18	O-RING	VITON	--	1
19	STOP PIN	304 SS	--	1
20	ANTI-STATIC DEVICE	304 SS	--	1

**TABLE 1:  
End Cap Bolt Torques**

VALVE SIZE	BODY BOLT TORQUE (IN LBS)
1/4"	398
3/8"	398
1/2"	398
3/4"	398
1"	398
1-1/4"	708
1-1/2"	1017
2"	1017

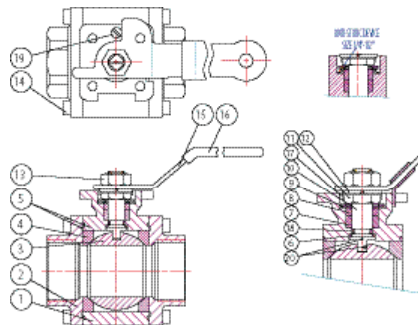

*To order a complete new valve, please refer to BI-TORQ price list for InstruPak valve replacement.*

COMPLETE VALVE PART NUMBER: FS/FW-3PT-\*\*\*  
 \*\*\*=VALVE SIZE (005=1/2", 007=3/4", 010=1", 012=1-1/4", 015=1-1/2", 020=2", 025=2-1/2", 030=3", 040=4")

<sup>1</sup> COMPLETE REPAIR KIT INCLUDES SEATS, SEALS AND O-RINGS