



THE ORIGINATOR OF PISTON-TYPE VALVES

# TANK BOTTOM/DRAIN VALVES

SOFT SEAL PISTON VALVES



 *Stahman*<sup>®</sup>  
PROCESS VALVES

# SERIES DV, STANDARD RANGE

## ORIGINAL STRAHMAN RAM-TYPE DRAIN VALVE

### FEATURES

- Quality System Registered to ISO 9001:2008 Certificate #003264
- Valve flanges meet the requirements of ANSI B16.5
- All valves manufactured in accordance to ASME/ANSI B16.34 standard
- All Valves 100% Leak Tested for bubble tight shut-off
- Vacuum pressure tested to 28 vacuum inches of mercury (0.94 PSIA) upon request
- Strahman 1-inch to 6-inch 150, 300, & 600 Class ANSI drain valves qualify by design to API Fire Test for Valves
- 3/16-inch RF on the inlet flange for mating to Strahman drain valve nozzles, adapters and inserts.
- 45° and 60° straight neck discharges are standard
- Packing Materials:
  - PTFE rated -328°F (-200°C) to 450°F (232°C)
  - MR to 650°F (343°C)
  - Graphite rated to 1000°F (538°C)
  - TFM 1600 rated -328°F (-200°C) to 450°F (232°C)

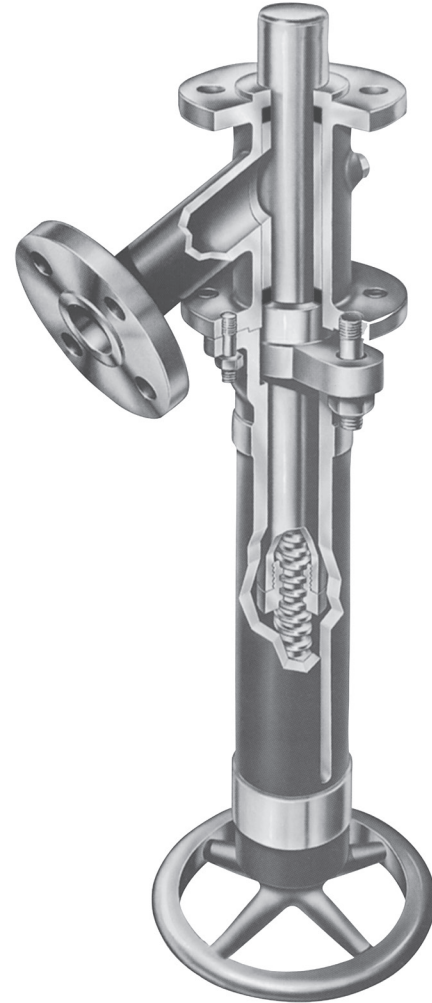

### AVAILABLE SIZES

- 1-inch, 2-inch and 3-inch, 900, 1100 and 1500 Class ANSI RF flanges\*
- 1-inch through 6-inch 150, 300 and 600 Class ANSI RF flanges\*
- 8-inch, 10-inch and 12-inch, 150 and 300 Class ANSI RF
- Optional flanges include DIN, British Standard, JIS, ANSI RJ, flat face and quick disconnect\*

### AVAILABLE OPERATORS

- Manual Handwheel
- Gear Operator
- Air Cylinder (with or without external switches)
- Hydraulic Cylinder (with or without external switches)
- Motor (electric or pneumatic) with external switches
- Multi-turn Electric Rotork motor with internal switches†

\* For 316 and 316L stainless steel pressure and temperature ratings see the tables below.  
For all other sizes and materials consult Strahman direct.

† Other multi-turn operators available upon request.

												316L MAX		
316	CL 150	Pressure	psig	275	235	215	195	170	140	110	80	50	35	65
		(barg)	(19.0)	(16.2)	(14.8)	(13.4)	(11.7)	(9.7)	(7.6)	(5.5)	(3.4)	(2.4)	(4.5)	
& 316L	Temperature	Deg. F	100	200	300	400	500	600	700	800	900	950	850	
		(Deg. C)	(37.8)	(93.3)	(148.9)	(204.4)	(260.0)	(315.6)	(371.1)	(426.7)	(482.2)	(510.0)	(454.4)	
												316L MAX		
316	CL 300	Pressure	psig	720	620	560	515	480	450	430	420	415	385	420
		(barg)	(49.7)	(42.8)	(38.6)	(35.5)	(33.1)	(31.0)	(29.7)	(29.0)	(27.6)	(26.6)	(29.0)	
& 316L	Temperature	Deg. F	100	200	300	400	500	600	700	800	900	950	850	
		(Deg. C)	(37.8)	(93.3)	(148.9)	(204.4)	(260.0)	(315.6)	(371.1)	(426.7)	(482.2)	(510.0)	(454.4)	
												316L MAX		
316	CL 600	Pressure	psig	1440	1240	1120	1025	955	900	870	845	830	775	835
		(barg)	(99.3)	(85.5)	(77.2)	(70.7)	(65.9)	(62.1)	(60.0)	(58.3)	(57.2)	(53.4)	(57.6)	
& 316L	Temperature	Deg. F	100	200	300	400	500	600	700	800	900	950	850	
		(Deg. C)	(37.8)	(93.3)	(148.9)	(204.4)	(260.0)	(315.6)	(371.1)	(426.7)	(482.2)	(510.0)	(454.4)	

# SERIES DV, STANDARD RANGE

## 1" & 1½" HAND OPERATED RISING STEM RAM-TYPE DRAIN VALVES

Part No.	Description	Std. Material
701	Hand Wheel Nut	304SST
702	Hand Wheel	Cast Iron
704	Bushing Lock Screw	304SST
705	Bushing	Bronze (SST Avail.)
706	Bonnet	304SST
707	Stem *	416SST
708	Gland	304SST
712	Bonnet Nut	316SST
713	Bonnet Stud	304SST
714	Gland Ring *	Braided TFE
715	Cage †	316SST
716	Split Nut *	316SST
717	Piston * †	316SST
718	Inlet Ring * †	TFE
720	Body †	316SST
724	Gland Nut	316SST
725	Gland Stud	304SST
731	Cage Lock †	316SST
740	Cage Lock Gasket * †	TFE
741	Opening Indicator	304SST

\* Indicates recommended spare parts

† Denotes wetted parts

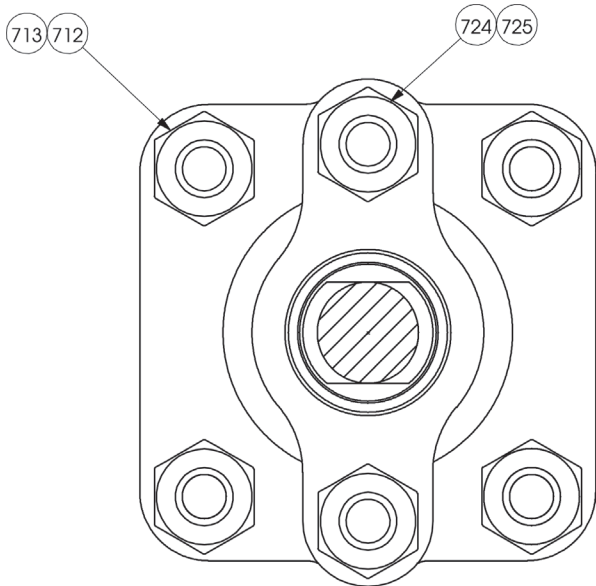
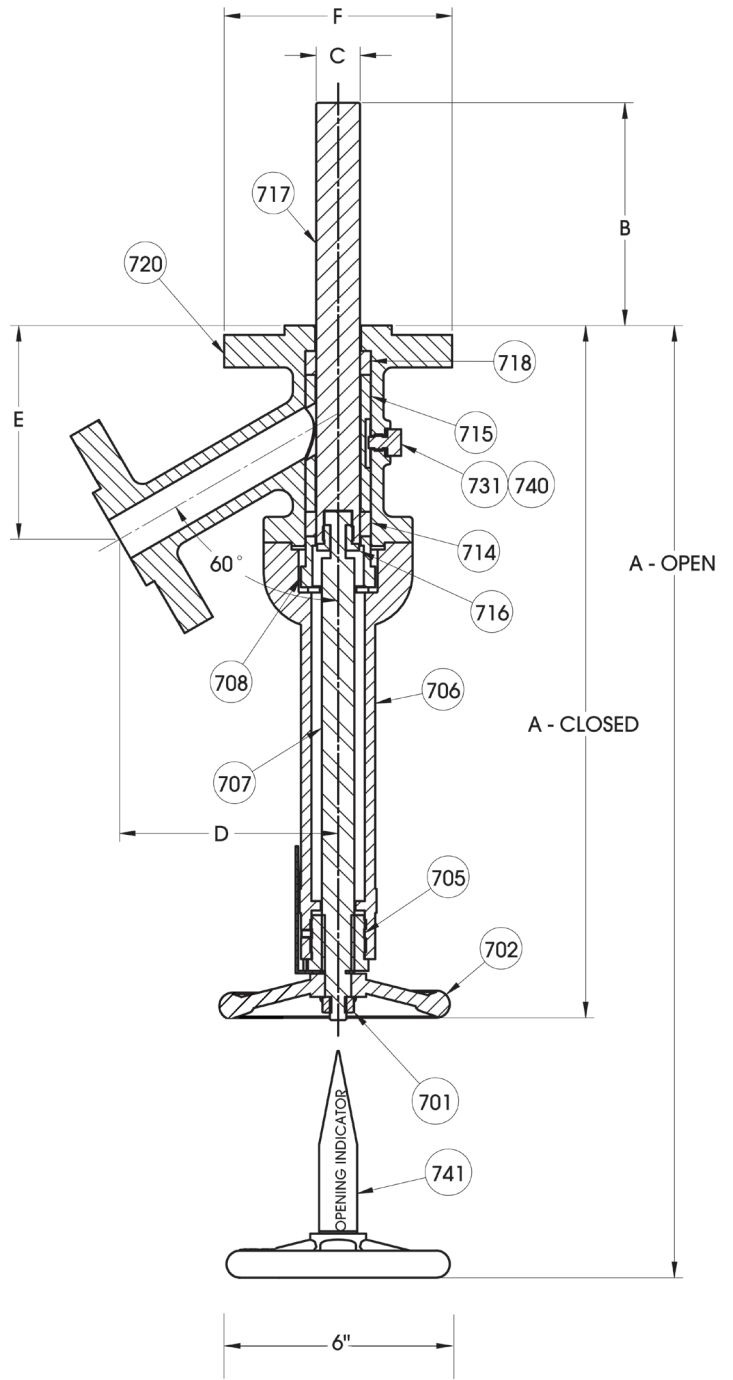

1" through 2 ½" Valve Body Deck

### CAUTION

When a Strahman adapter is not supplied with the drain valve, or the customer's nozzle does not have a piloting recess, the nozzle bore must be ¼" larger than the piston diameter. This clearance prevents the piston from scoring on the inside of the nozzle which could cause the valve to leak.

# STANDARD DIMENSIONS FOR 1" & 1½" HAND OPERATED RISING STEM RAM-TYPE DRAIN VALVES

1" Drain Valve with Standard 60 Degree Straight Neck Discharge							
Pressure Class	A Closed	A Open	B ± 1/8"	C ± .002"	D	E	F
ANSI Class 150	12 ¼"	16 ½"	2"	0.984"	4 ⅞"	3 ¾"	4 ¼"
	14 ¼"	20 ½"	4"	0.984"	4 ⅞"	3 ¾"	4 ¼"
	16 ¼"	24 ½"	6"	0.984"	4 ⅞"	3 ¾"	4 ¼"
	18 ¼"	28 ½"	8"	0.984"	4 ⅞"	3 ¾"	4 ¼"
	22 ¼"	36 ½"	12"	0.984"	4 ⅞"	3 ¾"	4 ¼"
ANSI Class 300	13"	17 1/16"	2"	0.984"	4 13/16"	4 9/16"	4 7/8"
	15"	21 1/16"	4"	0.984"	4 13/16"	4 9/16"	4 7/8"
	17"	25 1/16"	6"	0.984"	4 13/16"	4 9/16"	4 7/8"
	19"	29 1/16"	8"	0.984"	4 13/16"	4 9/16"	4 7/8"
	23"	37 1/16"	12"	0.984"	4 13/16"	4 9/16"	4 7/8"
ANSI Class 600	13 3/16"	18 1/8"	2"	0.984"	5"	4 7/8"	4 7/8"
	15 3/16"	22 1/8"	4"	0.984"	5"	4 7/8"	4 7/8"
	17 3/16"	26 1/8"	6"	0.984"	5"	4 7/8"	4 7/8"
	19 3/16"	30 1/8"	8"	0.984"	5"	4 7/8"	4 7/8"
	23 3/16"	38 1/8"	12"	0.984"	5"	4 7/8"	4 7/8"

1 ½" Drain Valve with Standard 60 Degree Straight Neck Discharge							
Pressure Class	A Closed	A Open	B ± 1/8"	C ± .002"	D	E	F
ANSI Class 150	13 5/8"	18 7/16"	2"	1.181"	5"	4 5/8"	5"
	15 5/8"	22 7/16"	4"	1.181"	5"	4 5/8"	5"
	17 5/8"	26 7/16"	6"	1.181"	5"	4 5/8"	5"
	19 5/8"	30 7/16"	8"	1.181"	5"	4 5/8"	5"
	23 5/8"	38 7/16"	12"	1.181"	5"	4 5/8"	5"
ANSI Class 300	14 5/16"	19 1/2"	2"	1.181"	5 5/8"	5 1/4"	6 1/8"
	16 5/16"	23 1/2"	4"	1.181"	5 5/8"	5 1/4"	6 1/8"
	18 5/16"	27 1/2"	6"	1.181"	5 5/8"	5 1/4"	6 1/8"
	20 5/16"	31 1/2"	8"	1.181"	5 5/8"	5 1/4"	6 1/8"
	24 5/16"	39 1/2"	12"	1.181"	5 5/8"	5 1/4"	6 1/8"
ANSI Class 600	14 5/8"	20 1/8"	2"	1.181"	5 7/8"	5 3/4"	6 1/8"
	16 5/8"	24 1/8"	4"	1.181"	5 7/8"	5 3/4"	6 1/8"
	18 5/8"	28 1/8"	6"	1.181"	5 7/8"	5 3/4"	6 1/8"
	20 5/8"	32 1/8"	8"	1.181"	5 7/8"	5 3/4"	6 1/8"
	24 5/8"	40 1/8"	12"	1.181"	5 7/8"	5 3/4"	6 1/8"

1" Drain Valve with Standard 45 Degree Straight Neck Discharge							
Pressure Class	A Closed	A Open	B ± 1/8"	C ± .002"	D	E	F
ANSI Class 150	14"	18 7/8"	2"	0.984	4 ½"	6 ¼"	4 ¼"
	16"	22 7/8"	4"	0.984	4 ½"	6 ¼"	4 ¼"
	18"	26 7/8"	6"	0.984	4 ½"	6 ¼"	4 ¼"
	20"	30 7/8"	8"	0.984	4 ½"	6 ¼"	4 ¼"
	24"	38 7/8"	12"	0.984	4 ½"	6 ¼"	4 ¼"
ANSI Class 300	14"	18 7/8"	2"	0.984	4 5/8"	6 3/8"	4 7/8"
	16"	22 7/8"	4"	0.984	4 5/8"	6 3/8"	4 7/8"
	18"	26 7/8"	6"	0.984	4 5/8"	6 3/8"	4 7/8"
	20"	30 7/8"	8"	0.984	4 5/8"	6 3/8"	4 7/8"
	24"	38 7/8"	12"	0.984	4 5/8"	6 3/8"	4 7/8"
ANSI Class 600	14"	18 7/8"	2"	0.984	4 ¾"	6 3/8"	4 7/8"
	16"	22 7/8"	4"	0.984	4 ¾"	6 3/8"	4 7/8"
	18"	26 7/8"	6"	0.984	4 ¾"	6 3/8"	4 7/8"
	20"	30 7/8"	8"	0.984	4 ¾"	6 3/8"	4 7/8"
	24"	38 7/8"	12"	0.984	4 ¾"	6 3/8"	4 7/8"

1 ½" Drain Valve with Standard 45 Degree Straight Neck Discharge							
Pressure Class	A Closed	A Open	B ± 1/8"	C ± .002"	D	E	F
ANSI Class 150	15 5/16"	21 1/8"	2"	1.181"	5 ¼"	7 7/16"	5"
	17 5/16"	25 1/8"	4"	1.181"	5 ¼"	7 7/16"	5"
	19 5/16"	29 1/8"	6"	1.181"	5 ¼"	7 7/16"	5"
	21 5/16"	33 1/8"	8"	1.181"	5 ¼"	7 7/16"	5"
	25 5/16"	41 1/8"	12"	1.181"	5 ¼"	7 7/16"	5"
ANSI Class 300	15 5/16"	21 1/8"	2"	1.181"	5 5/16"	7 9/16"	6 1/8"
	17 5/16"	25 1/8"	4"	1.181"	5 5/16"	7 9/16"	6 1/8"
	19 5/16"	29 1/8"	6"	1.181"	5 5/16"	7 9/16"	6 1/8"
	21 5/16"	33 1/8"	8"	1.181"	5 5/16"	7 9/16"	6 1/8"
	25 5/16"	41 1/8"	12"	1.181"	5 5/16"	7 9/16"	6 1/8"
ANSI Class 600	15 1/2"	21	2"	1.181"	5 1/2"	7 5/8"	6 1/8"
	17 1/2"	25	4"	1.181"	5 1/2"	7 5/8"	6 1/8"
	19 1/2"	29	6"	1.181"	5 1/2"	7 5/8"	6 1/8"
	21 1/2"	33	8"	1.181"	5 1/2"	7 5/8"	6 1/8"
	25 1/2"	41	12"	1.181"	5 1/2"	7 5/8"	6 1/8"

\* Strahman piston extensions are measured from the height of the RF for an ANSI standard flange. For ANSI 600 class valves the extension is equal to the actual RF provided by Strahman. For ANSI 150 and 300 class valves the ANSI standard RF height is 1/8" while Strahman provides 3/16" height for piloting as standard. Customers can request a 1/16" RF height for RF-to-RF flange installation and the piston extension will equal the actual distance from the RF. For the Strahman standard (3/16" height) the distance measured from the RF to the tip of the piston will be 1/16" less than the description. Example: 2" ANSI 150 Drain Valve with 6" piston extension will measure 5 7/8" from a standard Strahman RF to the tip of the piston. Piston extension tolerances tighter than 1/8" available upon request.

# SERIES DV, STANDARD RANGE

## HAND OPERATED TELESCOPING STEM RAM-TYPE DRAIN VALVES

Part No.	Description	Std. Material
701	Hand Wheel Nut	304SST
702	Hand Wheel	Cast Iron
704	Bushing Lock Screw	304SST
705	Bushing *	303SST
706	Bonnet	Carbon Steel
707	Stem *	416SST
708	Gland	304SST
711	Crosshead*	Bronze (SST Avail.)
712	Bonnet Nut	316SST
713	Bonnet Stud	304SST
714	Gland Ring *	Braided TFE
715	Cage †	316SST
717	Piston * †	316SST
718	Inlet Ring * †	TFE
720	Body †	316SST
724	Gland Nut	316SST
725	Gland Stud	304SST
726	Bearing Collar	303SST
727	Bearing *	Carbon Steel
731	Cage Lock †	316SST
732	Stop Collar	303SST
733	Collar Pin	304SST
734	Stem Guide	304SST
735	Guide Screws	304SST
737	Bearing Retainer	303SST
738	Bearing Seal	TFE
739	Piston Set Screw	304SST
740	Cage Lock Gasket * †	TFE
773	Grease Fitting	Steel

\* Indicates recommended spare parts  
 † Denotes wetted parts

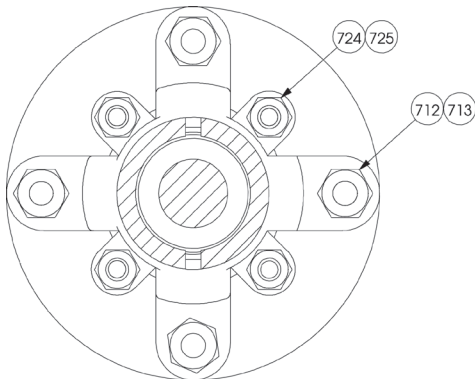
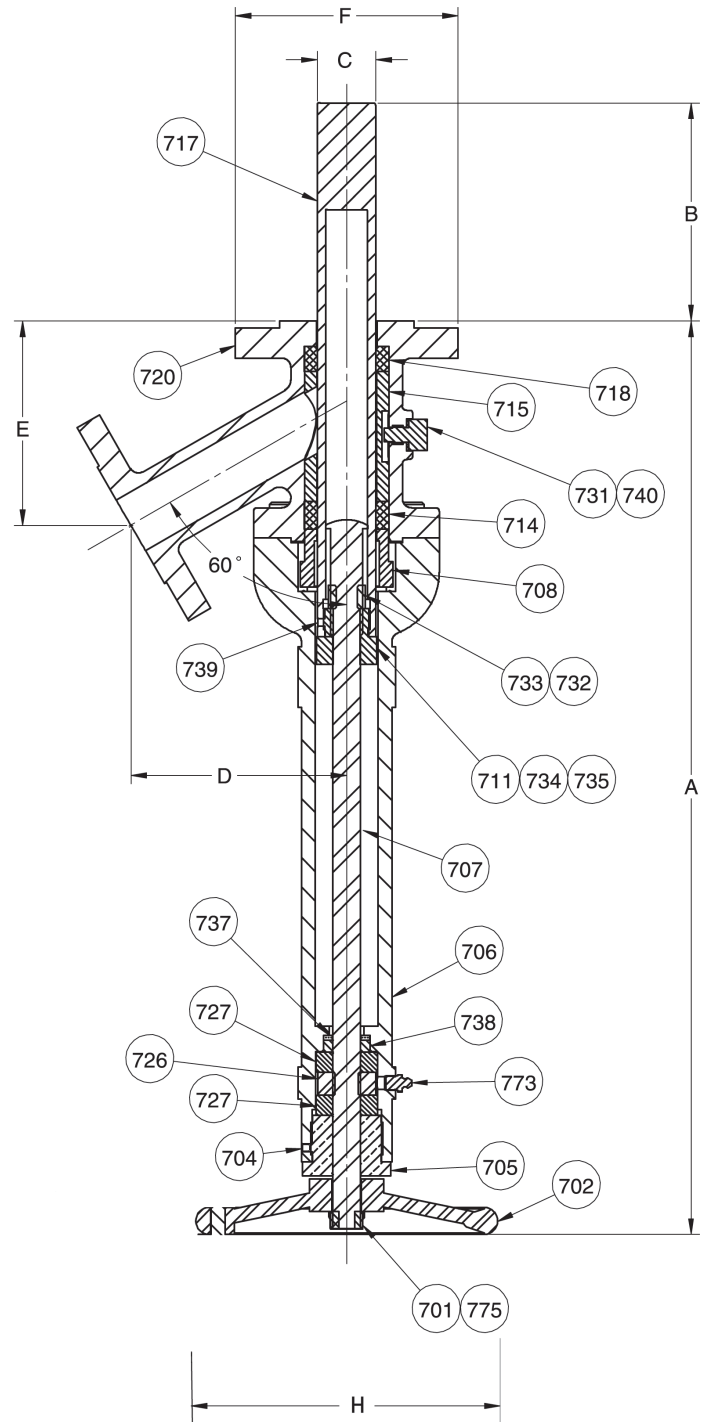

3" and Larger Valve Body Deck

### CAUTION

When a Strahman adapter is not supplied with the drain valve, or the customer's nozzle does not have a piloting recess, the nozzle bore must be 1/4" larger than the piston diameter. This clearance prevents the piston from scoring on the inside of the nozzle which could cause the valve to leak.

# STANDARD DIMENSIONS FOR HAND OPERATED TELESCOPING STEM RAM-TYPE DRAIN VALVES

ANSI Class 150 Drain Valve with standard 60 Degree Straight Neck Discharge									
Valve Size	A Std.	B ± 1/8"*	C ± .002"	D	E	F	H	A Max.	B Max.
2"	23"	6"	1.575"	5 13/16"	5 1/4"	6"	8 1/8"	29"	12"
2 1/2"	23 7/8"	6"	1.968"	6 1/4"	5 3/4"	7"	8 1/8"	29 7/8"	12"
3"	26 7/8"	6"	2.362"	7 3/8"	6 5/8"	7 1/2"	10 3/4"	32 7/8"	12"
4"	29 5/8"	6"	3.149"	8 3/8"	7 1/2"	9"	10 3/4"	35 5/8"	12"
6"	39 1/4"	6"	4.921"	11"	10 1/2"	11"	18"	42 1/4"	9"

ANSI Class 150 Drain Valve with standard 45 Degree Straight Neck Discharge									
Valve Size	A Std.	B ± 1/8"*	C ± .002"	D	E	F	H		
2"	26 3/8"	6"	1.575"	6 1/2"	8 3/8"	6"	8 1/8"		
3"	31 3/8"	6"	2.362"	8 5/8"	11"	7 1/2"	10 3/4"		
4"	34 7/8"	6"	3.149"	10 3/8"	12 3/4"	9"	10 3/4"		
6"	45 13/16"	6"	4.921"	13 3/8"	17 3/8"	11"	18"		

ANSI Class 150 Drain Valve with standard 90 Degree Straight Neck Discharge									
Valve Size	A Std.	B ± 1/8"*	C ± .002"	D	E	F	H	A Max.	B Max.
4"	38 7/8"	6"	3.149"	6 3/4"	6 3/4"	9"	10 3/4"	38 1/2"	6"
6"	39 3/8"	0"	4.921"	8 3/4"	7 1/4"	11"	18"	39 5/8"	7 1/2"

ANSI Class 300 Drain Valve with standard 60 Degree Straight Neck Discharge									
Valve Size	A Std.	B ± 1/8"*	C ± .002"	D	E	F	H	A Max.	B Max.
2"	23 1/2"	5 1/2"	1.575"	6 1/8"	5 15/16"	6 1/2"	8 1/8"	29 1/2"	11 1/2"
3"	27 3/8"	5 1/2"	2.362"	7 1/4"	7"	8 1/4"	10 3/4"	33 3/8"	11 1/2"
4"	30 1/8"	5 1/2"	3.149"	8 3/4"	8 3/8"	10"	10 3/4"	36 1/8"	11 1/2"
6"	39 5/8"	5 7/8"	4.921"	12"	11"	12 1/2"	18"	39 5/8"	5 7/8"

ANSI Class 300 Drain Valve with standard 45 Degree Straight Neck Discharge									
Valve Size	A Std.	B ± 1/8"*	C ± .002"	D	E	F	H		
2"	26 3/8"	6"	1.575"	6 1/2"	8 1/2"	6 1/2"	8 1/8"		
3"	31 1/2"	6"	2.362"	8 5/8"	11 1/4"	8 1/4"	10 3/4"		
4"	34 3/4"	6"	3.149"	10 3/8"	13 1/8"	10"	10 3/4"		
6"	46 3/8"	6"	4.921"	13 5/8"	17 3/4"	12 1/2"	18"		

ANSI Class 600 Drain Valve with standard 60 Degree Straight Neck Discharge									
Valve Size	A Std.	B ± 1/8"*	C ± .002"	D	E	F	H	A Max.	B Max.
2"	25 1/2"	6"	1.575"	6 11/16"	6 3/8"	6 1/2"	8 1/8"	25 1/2"	6"
3"	29 1/2"	6"	2.362"	8 7/8"	8"	8 1/4"	10 3/4"	29 1/2"	6"
4"	33 1/2"	6"	3.149"	10"	9 5/8"	10 3/4"	10 3/4"	33 1/2"	6"
6"	44 1/8"	6"	4.921"	12 7/8"	12"	14"	18"	44 1/8"	6"

ANSI Class 600 Drain Valve with standard 45 Degree Straight Neck Discharge									
Valve Size	A Std.	B ± 1/8"*	C ± .002"	D	E	F	H		
2"	26 1/2"	6"	1.575"	6 1/2"	8 3/4"	6 1/2"	8 1/8"		
3"	31 11/16"	6"	2.362"	8 5/8"	11 7/16"	8 1/4"	10 3/4"		
4"	35"	6"	3.149"	10 3/8"	13 1/8"	10 3/4"	10 3/4"		
6"	46 1/8"	6"	4.921"	13 5/8"	18 1/4"	14"	18"		

\* Strahman piston extensions are measured from the height of the RF for an ANSI standard flange. For ANSI 600 class valves the extension is equal to the actual RF provided by Strahman. For ANSI 150 and 300 class valves the ANSI standard RF height is 1/16" while Strahman provides 3/16" height for piloting as standard. Customers can request a 1/16" RF height for RF-to-RF flange installation and the piston extension will equal the actual distance from the RF. For the Strahman standard (3/16" height) the distance measured from the RF to the tip of the piston will be 1/8" less than the description. Example: 2" ANSI 150 Drain Valve with 6" piston extension will measure 5 7/8" from a standard Strahman RF to the tip of the piston. Piston Extension tolerances tighter than 1/8" available upon request.

# SERIES DV, STANDARD RANGE

## AIR CYLINDER OPERATED RAM-TYPE DRAIN VALVES

Part No.	Description	Std. Material
706	Bonnet	Carbon Steel
708	Gland	304SST
712	Bonnet Nut	316SST
713	Bonnet Stud	304SST
714	Gland Ring *	Braided TFE
715	Cage †	316SST
717	Piston * †	316SST
718	Inlet Ring * †	TFE
720	Body †	316SST
724	Gland Nut	316SST
725	Gland Stud	304SST
731	Cage Lock †	316SST
739	Piston Set Screw	304SST
740	Cage Lock Gasket * †	TFE
753	Piston Connector *	Bronze (SST Avail.)
757	Air Cylinder	
759	Cylinder Stud	304SST
760	Cylinder Nut	316SST

\* Indicates recommended spare parts  
 † Denotes wetted parts

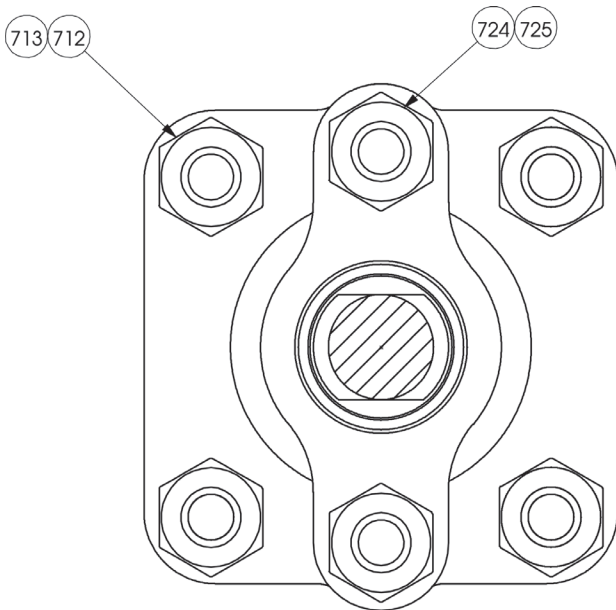
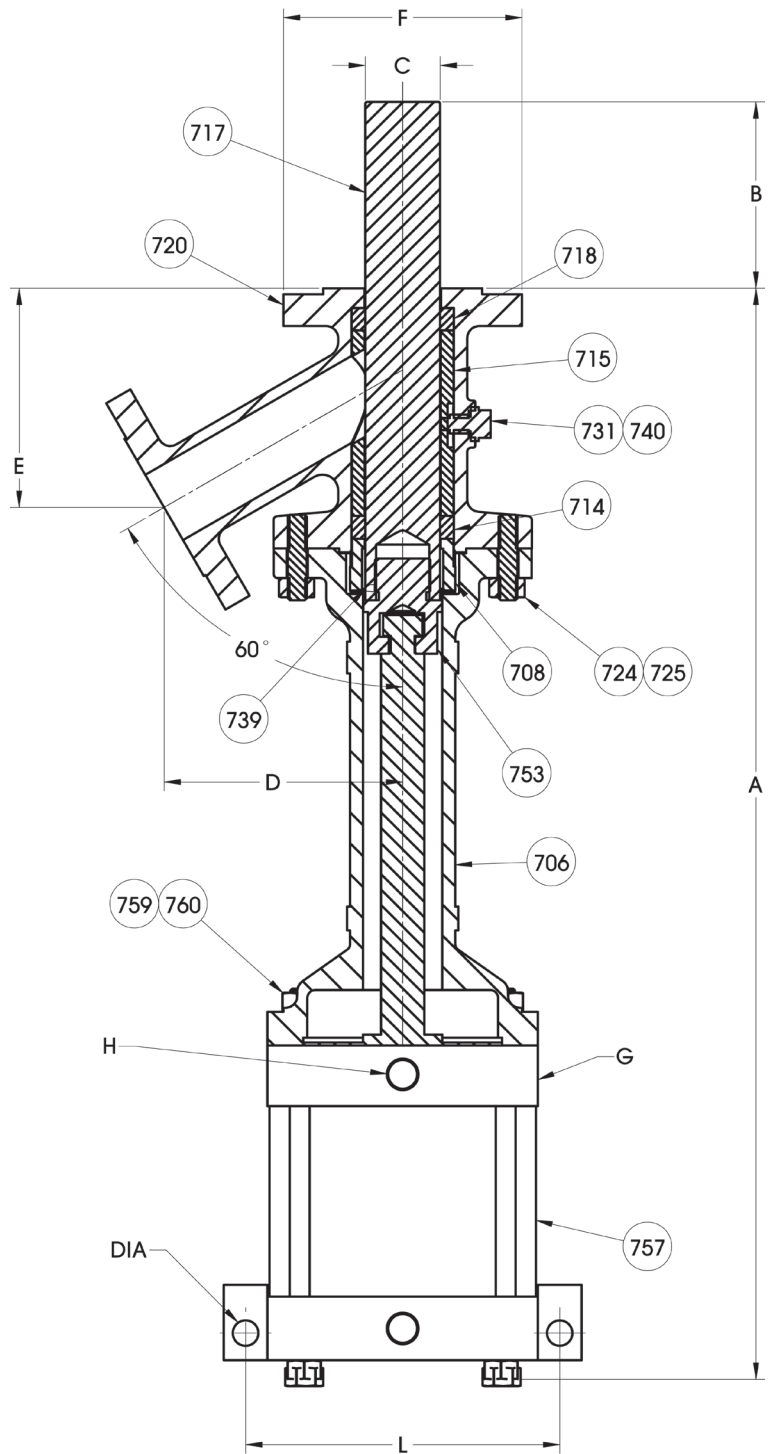

1" through 2 1/2" Valve Body Deck

### CAUTION

When a Strahman adapter is not supplied with the drain valve, or the customer's nozzle does not have a piloting recess, the nozzle bore must be 1/4" larger than the piston diameter. This clearance prevents the piston from scoring on the inside of the nozzle which could cause the valve to leak.

## DIMENSIONS FOR AIR OPERATED RAM-TYPE DRAIN VALVES

ANSI Class 150 Drain Valve with standard 60 Degree Straight Neck Discharge										
Valve Size	A Std.	B ± 1/8"	C ± .002"	D	E	F	G*(NPT)	H*(NPT)	L*	DIA.
1"	22"	2"	0.984"	4 1/4"	3 15/16"	4 1/4"	1/8"	1/2"	5 1/2"	9/16"
1 1/2"	24"	2"	1.181"	5"	4 5/8"	5"	1/8"	1/2"	6 7/8"	13/16"
2"	34 7/8"	6"	1.575"	5 13/16"	5 3/8"	6"	1/8"	3/4"	7 7/8"	13/16"
2 1/2"	38 9/16"	6"	1.968"	6 13/16"	6 5/8"	7"	1/8"	3/4"	7 7/8"	13/16"
3"	40"	6"	2.362"	7 1/2"	6 3/4"	7 1/2"	1/4"	3/4"	9 7/8"	13/16"
4"	46 1/16"	6"	3.149"	8 13/16"	7 15/16"	9"	1/4"	1"	12 3/8"	1 1/16"
6"	56 1/8"	6"	4.921"	11"	10 3/8"	11"	1/4"	1"	14 1/2"	1 1/16"
8"	66 15/16"	6"	5.905"	12 13/16"	11 7/8"	13 1/2"	1/4"	1"	14 1/2"	1 1/16"

ANSI Class 150 Drain Valve with standard 45 Degree Straight Neck Discharge										
Valve Size	A Std.	B ± 1/8"	C ± .002"	D	E	F	G*(NPT)	H*(NPT)	L*	DIA.
1"	24 3/8"	2"	0.984"	4 1/2"	6 1/4"	4 1/4"	1/8"	1/2"	5 1/2"	9/16"
1 1/2"	26 3/4"	2"	1.181"	5 1/4"	7 7/16"	5"	1/8"	1/2"	6 7/8"	13/16"
2"	37"	6"	1.575"	6 1/2"	8 3/8"	6"	1/8"	3/4"	7 7/8"	13/16"
3"	48"	6"	2.362"	8 5/8"	11"	7 1/2"	1/4"	3/4"	9 7/8"	13/16"
4"	49 1/8"	6"	3.149"	10 3/8"	12 3/4"	9"	1/4"	1"	12 3/8"	1 1/16"
6"	60 5/8"	6"	4.921"	13 5/8"	17 3/8"	11"	1/4"	1"	14 1/2"	1 1/16"

ANSI Class 300 Drain Valve with standard 60 Degree Straight Neck Discharge										
Valve Size	A Std.	B ± 1/8"	C ± .002"	D	E	F	G*(NPT)	H*(NPT)	L*	DIA.
1"	23 1/4"	2"	0.984"	4 7/8"	4 5/8"	4 7/8"	1/8"	1/2"	5 1/2"	9/16"
1 1/2"	24 1/4"	2"	1.181"	5 5/8"	5 1/4"	6 1/8"	1/8"	1/2"	6 7/8"	13/16"
2"	35 1/8"	5 5/8"	1.575"	6 1/8"	5 15/16"	6 1/2"	1/8"	3/4"	7 7/8"	13/16"
2 1/2"	38 13/16"	6"	1.968"	6 7/8"	6 13/16"	7 1/2"	1/8"	3/4"	7 7/8"	13/16"
3"	40 3/8"	5 5/8"	2.362"	8 1/16"	7 1/2"	8 1/4"	1/4"	3/4"	9 7/8"	1 1/16"
4"	46 7/8"	5 3/8"	3.149"	9 1/16"	8 13/16"	10"	1/4"	1"	12 3/8"	1 1/16"
6"	56 1/8"	6"	4.921"	12"	11"	12 1/2"	1/4"	1"	14 1/2"	1 1/16"

ANSI Class 300 Drain Valve with standard 45 Degree Straight Neck Discharge										
Valve Size	A Std.	B ± 1/8"	C ± .002"	D	E	F	G*(NPT)	H*(NPT)	L*	DIA.
1"	24 3/8"	2"	0.984"	4 5/8"	6 3/8"	4 7/8"	1/8"	1/2"	5 1/2"	9/16"
1 1/2"	27"	2"	1.181"	5 5/16"	7 9/16"	6 1/8"	1/8"	1/2"	6 7/8"	13/16"
2"	37 3/8"	6"	1.575"	6 1/2"	8 1/2"	6 1/2"	1/8"	3/4"	7 7/8"	13/16"
3"	48 3/8"	6"	2.362"	8 5/8"	11 1/4"	8 1/4"	1/4"	3/4"	9 7/8"	1 1/16"
4"	49 1/2"	6"	3.149"	10 3/8"	13 1/16"	10"	1/4"	1"	12 3/8"	1 1/16"
6"	61 1/2"	6"	4.921"	13 3/8"	17 3/4"	12 1/2"	1/4"	1"	14 1/2"	1 1/16"

ANSI Class 600 Drain Valve with standard 60 Degree Straight Neck Discharge										
Valve Size	A Std.	B ± 1/8"	C ± .002"	D	E	F	G*(NPT)	H*(NPT)	L*	DIA.
1"	23 5/8"	2"	0.984"	5"	4 7/8"	4 7/8"	1/8"	1/2"	5 1/2"	9/16"
1 1/2"	25 7/8"	2"	1.181"	5 7/8"	5 3/4"	6 1/8"	1/8"	1/2"	6 7/8"	13/16"
2"	36 15/16"	6"	1.575"	6 11/16"	6 9/16"	6 1/2"	1/8"	3/4"	7 7/8"	13/16"
3"	47 15/16"	6"	2.362"	8 7/16"	8"	8 1/4"	1/4"	1"	9 7/8"	1 1/16"
4"	53 7/8"	6"	3.149"	10"	9 5/8"	10 3/4"	1/4"	1"	12 3/8"	1 1/16"

ANSI Class 600 Drain Valve with standard 45 Degree Straight Neck Discharge										
Valve Size	A Std.	B ± 1/8"	C ± .002"	D	E	F	G*(NPT)	H*(NPT)	L*	DIA.
1"	24 1/2"	2"	0.984"	4 3/4"	6 3/8"	4 7/8"	1/8"	1/2"	5 1/2"	9/16"
1 1/2"	26 5/8"	2"	1.181"	5 1/2"	7 5/8"	6 1/8"	1/8"	1/2"	6 7/8"	13/16"
2"	37 7/8"	6"	1.575"	6 1/2"	8 3/8"	6 1/2"	1/8"	3/4"	7 7/8"	13/16"
3"	50 1/2"	6"	2.362"	8 5/8"	11 1/16"	8 1/4"	1/4"	1"	9 7/8"	1 1/16"
4"	51"	6"	3.149"	10 3/8"	13 1/16"	10 3/4"	1/4"	1"	12 3/8"	1 1/16"
6"	62 5/8"	6"	4.921"	13 3/8"	18 1/4"	14"	1/4"	1"	14 1/2"	1 1/16"

\* Dimensions G, H, L are for Air-Operated Drain Valves. For Hydraulic Drain Valve dimensions, please consult factory. Strahman piston extensions are measured from the height of the RF for an ANSI standard flange. For ANSI 600 class valves the extension is equal to the actual RF provided by Strahman. For ANSI 150 and 300 class valves the ANSI standard RF height is 1/16" while Strahman provides 3/16" height for piloting as standard. Customers can request a 1/16" RF height for RF-to-RF flange installation and the piston extension will equal the actual distance from the RF. For the Strahman standard (3/16" height) the distance measured from the RF to the tip of the piston will be 1/8" less than the description. Example: 2" ANSI 150 Drain Valve with 6" piston extension will measure 5 7/8" from a standard Strahman RF to the tip of the piston. Piston Extension tolerances tighter than 1/8" available upon request.

# SERIES DV, STANDARD RANGE

## AIR AND HYDRAULIC OPERATED RAM-TYPE DRAIN VALVES WITH INDICATOR SWITCHES

Part No.	Description	Std. Material
706	Bonnet	Carbon Steel
708	Gland	304SST
712	Bonnet Nut	316SST
713	Bonnet Stud	304SST
714	Gland Ring *	Braided TFE
715	Cage †	316SST
717	Piston * †	316SST
718	Inlet Ring * †	TFE
720	Body †	316SST
724	Gland Nut	316SST
725	Gland Stud	304SST
731	Cage Lock †	316SST
733	Collar Pin **	304SST
735	Switch Trip Screw	304SST
739	Piston Set Screw	304SST
740	Cage Lock Gasket * †	TFE
753	Piston Connector *	Bronze (SST Avail.)
754	Indicator Switch	
755	Switch Bracket	304SST
757	Cylinder	
759	Cylinder Stud	304SST
760	Cylinder Nut	316SST
761	Switch Trip	304SST
762	Piston Connector Nut**	304SST
780	Bracket Mtg. Screw	304SST
781	Switch Mtg. Screw	304SST

\* Indicates recommended spare parts

\*\* Collar Pin #733 and Piston Connector Nut #762 not shown, only for Hydraulic.

† Denotes wetted parts

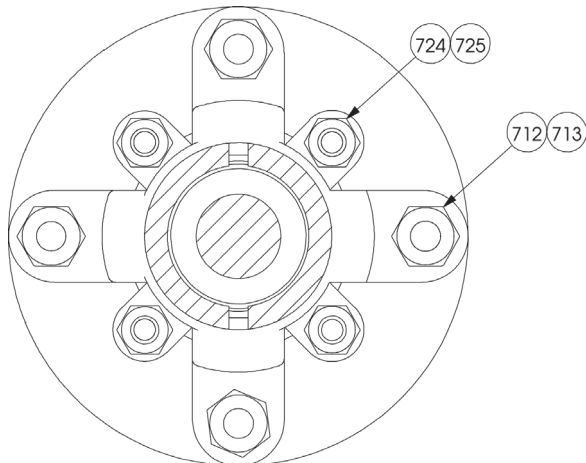
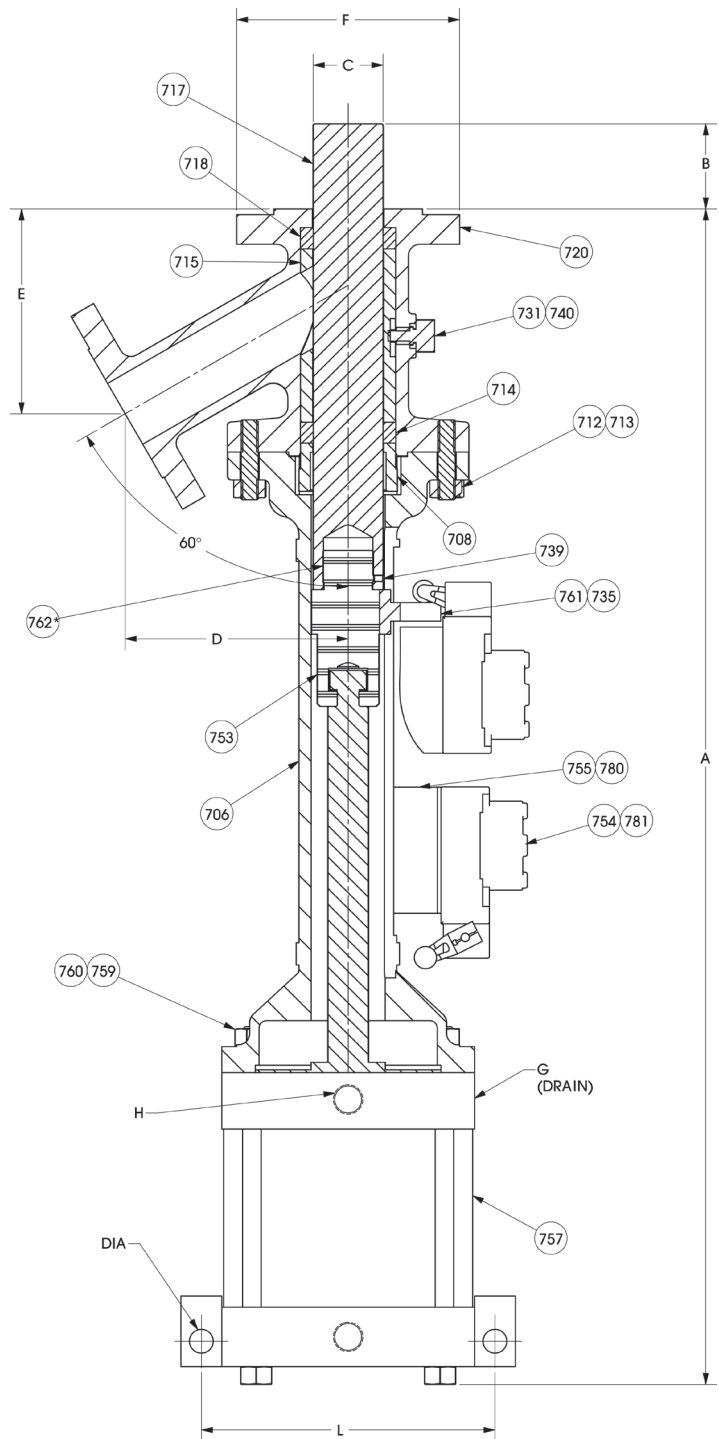

3" and Larger Valve Body Deck

### CAUTION

When a Strahman adapter is not supplied with the drain valve, or the customer's nozzle does not have a piloting recess, the nozzle bore must be 1/4" larger than the piston diameter. This clearance prevents the piston from scoring on the inside of the nozzle which could cause the valve to leak.

# DIMENSIONS FOR AIR AND HYDRAULIC CYLINDER OPERATED RAM-TYPE DRAIN VALVES WITH SWITCHES

ANSI Class 150 Drain Valve with standard 45 Degree Straight Neck Discharge						
Valve Size	A Std.	B ± 1/8"	C ± .002"	D	E	F
1"	35 7/8"	6"	0.984"	4 1/2"	6 1/4"	4 1/4"
1 1/2"	38 13/16"	6"	1.181"	5 1/4"	7 1/16"	5"
2"	43 1/2"	6"	1.575"	6 1/2"	8 3/8"	6"
3"	48"	6"	2.362"	8 5/8"	11"	7 1/2"
4"	53 15/16"	6"	3.149"	10 3/8"	12 3/4"	9"
6"	66 7/8"	6"	4.921"	13 5/8"	17 3/8"	11"

Air Switch with 60 Degree Straight Neck Discharge		
Valve Size	A Std.	B ± 1/8"
1"	33 13/16"	6"
1 1/2"	36 3/8"	6"
2"	42 11/16"	6"
2 1/2"	43 3/8"	6"
3"	45 1/4"	6"
4"	51 1/8"	6"
6"	62 3/8"	6"
8"	66 15/16"	6"

Hydraulic Operated with 60 Degree Straight Neck		
Valve Size	A Std.	B ± 1/8"
1"	33 13/16"	6"
1 1/2"	36 3/8"	6"
2"	42 11/16"	6"
2 1/2"	41 11/16"	6"
3"	43 3/8"	6"
4"	46 3/16"	6"
6"	57 3/8"	6"
8"	64 1/2"	6"
10"	75 1/16"	6"
12"	96"	6"

ANSI Class 300 Drain Valve with standard 45 Degree Straight Neck Discharge						
Valve Size	A Std.	B ± 1/8"	C ± .002"	D	E	F
1"	35 7/8"	6"	0.984"	4 5/8"	6 3/8"	4 7/8"
1 1/2"	38 13/16"	6"	1.181"	5 5/16"	7 3/16"	6 1/8"
2"	43 7/8"	6"	1.575"	6 1/2"	8 1/2"	6 1/2"
3"	48 3/8"	6"	2.362"	8 5/8"	11 1/4"	8 1/4"
4"	54 3/8"	6"	3.149"	10 3/8"	13 1/16"	10"
6"	67 3/4"	6"	4.921"	13 5/8"	17 3/4"	12 1/2"

Air Switch with 60 Degree Straight Neck Discharge		
Valve Size	A Std.	B ± 1/8"
1"	34 3/4"	6"
1 1/2"	37 5/16"	6"
2"	43 3/16"	6"
2 1/2"	43 3/8"	6"
3"	45 11/16"	5 5/8"
4"	52 1/4"	6"
6"	62 3/8"	6"

Hydraulic Operated with 60 Degree Straight Neck		
Valve Size	A Std.	B ± 1/8"
1"	34 3/4"	6"
1 1/2"	37 5/16"	6"
2"	43 3/16"	6"
2 1/2"	41 11/16"	6"
3"	44 1/16"	6"
4"	47 3/16"	6"
6"	57 3/8"	6"
8"	65 1/2"	6"
10"	75 1/16"	6"
12"	96"	6"

ANSI Class 600 Drain Valve with standard 45 Degree Straight Neck Discharge						
Valve Size	A Std.	B ± 1/8"	C ± .002"	D	E	F
1"	35 7/8"	6"	0.984"	4 3/4"	6 3/8"	4 7/8"
1 1/2"	38 3/4"	6"	1.181"	5 1/2"	7 5/8"	6 1/8"
2"	44 3/8"	6"	1.575"	6 1/2"	8 3/4"	6 1/2"
3"	50 1/4"	6"	2.362"	8 5/8"	11 1/16"	8 1/4"
4"	55 13/16"	6"	3.149"	10 3/8"	13 1/16"	10 3/4"
6"	68 7/8"	6"	4.921"	13 5/8"	18 1/4"	14"

Air Switch with 60 Degree Straight Neck Discharge		
Valve Size	A Std.	B ± 1/8"
1"	35 1/8"	6"
1 1/2"	37 15/16"	6"
2"	43 7/16"	6"
3"	47 1/4"	5 5/16"
4"	54 "	6"

Hydraulic Operated with 60 Degree Straight Neck		
Valve Size	A Std.	B ± 1/8"
1"	35 1/8"	6"
1 1/2"	37 15/16"	6"
2"	43 7/16"	6"
3"	44 11/16"	6"
4"	50 3/8"	6"
6"	59 3/8"	6"

\* Strahman piston extensions are measured from the height of the RF for an ANSI standard flange. For ANSI 600 class valves the extension is equal to the actual RF provided by Strahman. For ANSI 150 and 300 class valves the ANSI standard RF height is 1/16" while Strahman provides 3/16" height for piloting as standard. Customers can request a 1/16" RF height for RF-to-RF flange installation and the piston extension will equal the actual distance from the RF. For the Strahman standard (3/16" height) the distance measured from the RF to the tip of the piston will be 1/8" less than the description. Example: 2" ANSI 150 Drain Valve with 6" piston extension will measure 5 7/8" from a standard Strahman RF to the tip of the piston. Piston Extension tolerances tighter than 1/8" available upon request.

# SERIES DV, STANDARD RANGE

## ELECTRIC ACTUATOR AND AIR MOTOR OPERATED

### RAM-TYPE DRAIN VALVES

Part No.	Description	Std. Material
704	Brushing Lock Screw	304SST
705	Insert/Bushing	Bronze /303SST
706	Bonnet	Carbon Steel
707	Stem *	416SST
708	Gland	304SST
711	Crosshead *	Bronze (SST Avail.)
712	Bonnet Nut	316SST
713	Bonnet Stud	304SST
714	Gland Ring *	Braided TFE
715	Cage †	316SST
717	Piston*†	316SST
718	Inlet Ring* †	TFE
720	Body †	316SST
724	Gland Nut	316SST
725	Gland Stud	304SST
726	Bearing Collar	303SST
727	Bearing*	Carbon Steel
731	Cage Lock †	316SST
732	Stem Stop	303SST
733	Stem Stop Pin	304SST
734	Crosshead Guide *	303SST
735	Switch Trip Screw *	304SST
737	Retaining Ring *	303SST
738	Bearing Seal *	TFE
739	Piston Set Screw	304SST
740	Cage Lock Gasket*	RTFE
754	Indicator Switch	
755	Switch Bracket	304SST
761	Switch Trip	304SST
763	Reducer Coupling	
764	Motor	
765	Gear Reducer	
773	Grease Fitting	Steel
780	Bracket Mtg. Screw	304SST
781	Switch Mtg. Screw	304SST
783	Key	
784	Reducer Mtg.Stud	304SST
785	Reducer Mtg. Nut	316SST
786	Reducer Mtg. Washer	304SST
787	Safety Shield	304SST
788	Safety Shield Screw	304SST
789	Safety Shield Washer	304SST
790	Stem Coupling	
791	Insert	Bronze

\* Denotes recommended spare parts  
 † Denotes wetted parts

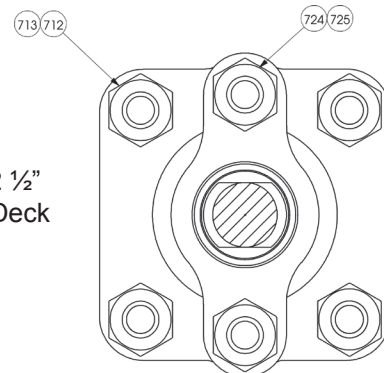
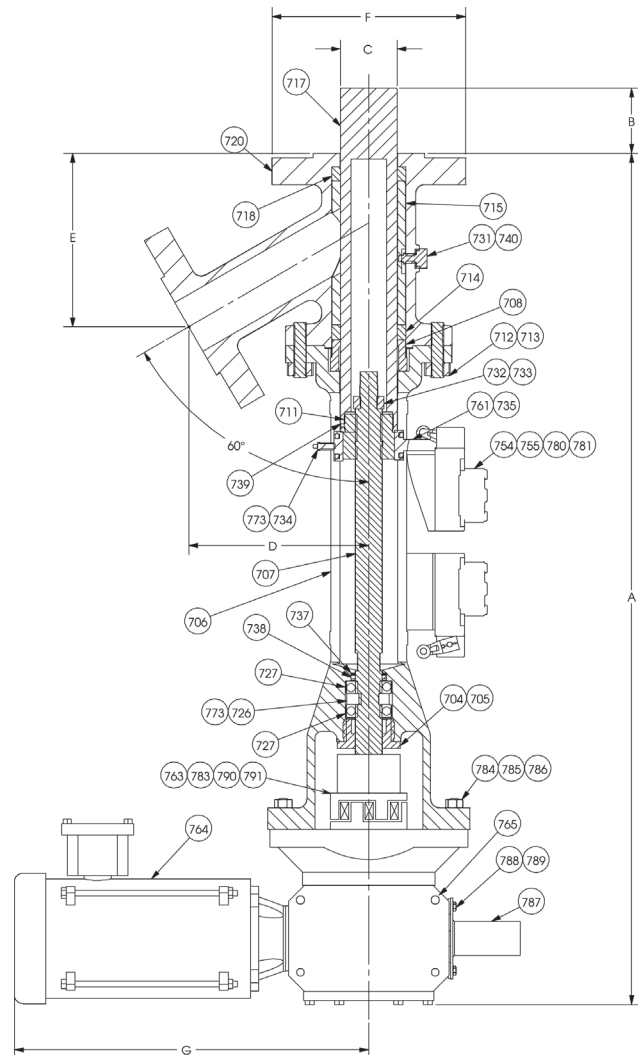

1" through 2 1/2"  
 Valve Body Deck

#### CAUTION

When a Strahman adapter is not supplied with the drain valve, or the customer's nozzle does not have a piloting recess, the nozzle bore must be 1/4" larger than the piston diameter. This clearance prevents the piston from scoring on the inside of the nozzle which could cause the valve to leak.

# STANDARD DIMENSIONS FOR ELECTRIC AND AIR MOTOR OPERATED RAM-TYPE DRAIN VALVES

ANSI Class 150 Drain Valve with standard 60 Degree Straight Neck Discharge									
Valve Size	A Std.	B ± 1/8"	C ± .002"	D	E	F	G	A Max.	B Max.
2"	41 13/16"	6"	1.575"	5 13/16"	5 3/8"	6"	18 13/16"	41 13/16"	6"
3"	46"	6"	2.362"	7 1/2"	6 3/4"	7 1/2"	18 13/16"	46"	6"
4"	47"	6"	3.149"	8 13/16"	7 15/16"	9"	18 13/16"	47"	6"
6"	55 3/8"	6"	4.921"	11"	10 3/8"	11"	18 13/16"	61 3/8"	12"
8"	61"	6"	5.905"	12 13/16"	11 5/8"	13 1/2"	18 13/16"	61"	6"
10"	72 3/4"	6"	7.480"	16 5/8"	15 5/8"	16"	18 13/16"	72 3/4"	6"

ANSI Class 150 Drain Valve with standard 45 Degree Straight Neck Discharge									
Contact Strahman factory for details									

ANSI Class 300 Drain Valve with standard 60 Degree Straight Neck Discharge									
Valve Size	A Std.	B ± 1/8"	C ± .002"	D	E	F	G	A Max.	B Max.
2"	42 3/16"	6"	1.575"	6 1/8"	5 15/16"	6 1/2"	18 13/16"	42 13/16"	6"
3"	46 3/8"	6"	2.362"	8 1/16"	7 1/2"	8 1/4"	18 13/16"	46 3/8"	6"
4"	47 1/2"	5 1/2"	3.149"	9 1/16"	8 13/16"	10"	18 13/16"	47 1/2"	5 1/2"
6"	55 3/8"	6"	4.921"	12"	11"	12 1/2"	18 13/16"	61 3/8"	12"
8"	61 1/2"	6"	5.905"	13 9/16"	12 13/16"	15"	18 13/16"	61 1/2"	6"
10"	72 3/4"	6"	7.480"	16 5/8"	15 5/8"	17 1/2"	20 9/16"	72 3/4"	6"

ANSI Class 600 Drain Valve with standard 60 Degree Straight Neck Discharge									
Valve Size	A Std.	B ± 1/8"	C ± .002"	D	E	F	G	A Max.	B Max.
2"	42 13/16"	6"	1.575"	6 1/16"	6 3/16"	6 1/2"	18 13/16"	42 13/16"	6"
3"	46 3/16"	6"	2.362"	8 7/16"	8"	8 1/4"	18 13/16"	46 3/16"	6"
4"	48 1/16"	4 15/16"	3.149"	10"	9 5/8"	10 3/4"	18 13/16"	48 1/16"	4 15/16"
6"	59 3/16"	6"	4.921"	12 1/8"	12"	14"	18 13/16"	59 3/16"	6"

\* Strahman piston extensions are measured from the height of the RF for an ANSI standard flange. For ANSI 600 class valves the extension is equal to the actual RF provided by Strahman. For ANSI 150 and 300 class valves the ANSI standard RF height is 1/16" while Strahman provides 3/16" height for piloting as standard. Customers can request a 1/16" RF height for RF-to-RF flange installation and the piston extension will equal the actual distance from the RF. For the Strahman standard (3/16" height) the distance measured from the RF to the tip of the piston will be 1/8" less than the description. Example: 2" ANSI 150 Drain Valve with 6" piston extension will measure 5 7/8" from a standard Strahman RF to the tip of the piston. Piston extension tolerances tighter than 1/8" available upon request.

# SERIES DV, STANDARD RANGE

## ROTORK OPERATED RAM-TYPE DRAIN VALVES

Part No.	Description	Std. Material
706	Bonnet	Carbon Steel
707	Stem *	416SST
708	Gland	304SST
711	Crosshead *	Bronze (SST Avail.)
712	Bonnet Nut	316SST
713	Bonnet Stud	304SST
714	Gland Ring * †	Braided TFE
715	Cage †	316SST
717	Piston * †	316SST
718	Inlet Ring * †	TFE
720	Body †	316SST
724	Gland Nut	316SST
725	Gland Stud	304SST
731	Cage Lock †	316SST
732	Stop Collar	303SST
733	Collar Pin	304SST
734	Crosshead Guide*	304SST
735	Guide Screw*	304SST
739	Piston Set Screw	304SST
740	Cage Lock Gasket*	TFE
768	Rotork Actuator	
769	Rotork Mtg. Stud	304SST
770	Rotork Mtg. Nut	316SST
771	Stem Washer	302SST
772	Stem Nut	304SST

\* Denotes recommended spare parts

† Denotes wetted parts

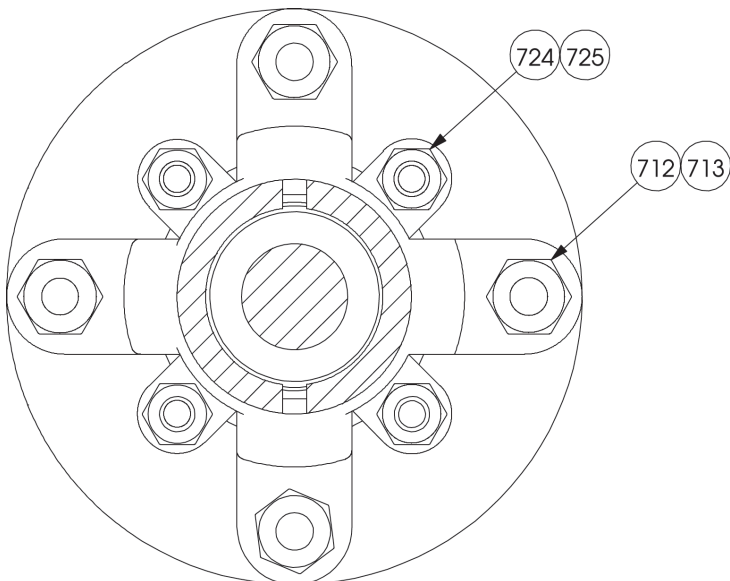
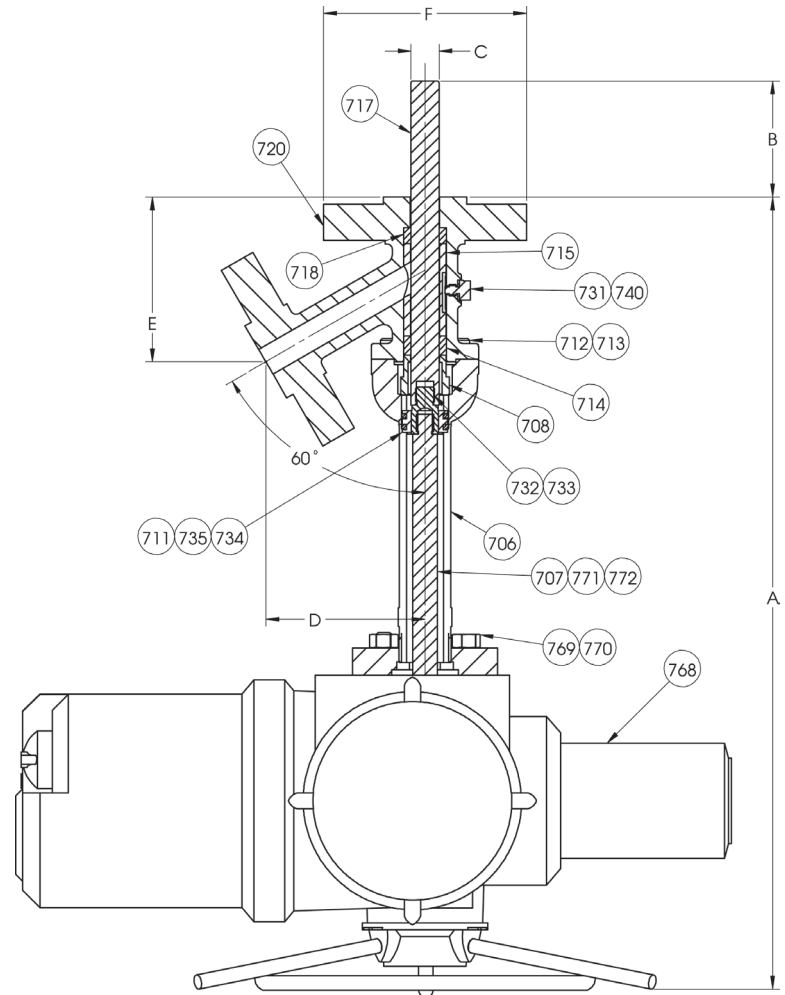

3" and Larger Valve Body Deck



Rotork Operated  
Drain Valve

### CAUTION

When a Strahman adapter is not supplied with the drain valve, or the customer's nozzle does not have a piloting recess, the nozzle bore must be 1/4" larger than the piston diameter. This clearance prevents the piston from scoring on the inside of the nozzle which could cause the valve to leak.

## STANDARD DIMENSIONS FOR ROTORK OPERATED RAM-TYPE DRAIN VALVES

ANSI Class 150 Drain Valve with standard 60 Degree Straight Neck Discharge						
Valve Size	A Std.	B ± 1/8"	C ± .002"	D	E	F
2"	35 1/16"	6"	1.575"	5 13/16"	5 3/8"	6"
3"	43 1/8"	6"	2.362"	7 1/2"	6 3/4"	7 1/2"
4"	45 1/16"	6"	3.149"	8 13/16"	7 15/16"	9"
6"	54 3/16"	6"	4.921"	11"	10 3/8"	11"
8"	62 3/8"	6"	5.905"	12 13/16"	11 1/8"	13 1/2"
10"	70 3/8"	6"	7.480"	16 5/8"	15 5/8"	16"

ANSI Class 150 Drain Valve with standard 45 Degree Straight Neck Discharge						
Contact Strahman factory for details						

ANSI Class 300 Drain Valve with standard 60 Degree Straight Neck Discharge						
Valve Size	A Std.	B ± 1/8"	C ± .002"	D	E	F
2"	36 5/8"	6"	1.575"	6 1/8"	5 15/16"	6 1/2"
3"	43 13/16"	6"	2.362"	8 1/16"	7 1/2"	8 1/4"
4"	46 1/16"	6"	3.149"	9 7/16"	8 13/16"	10"
6"	56 1/16"	6"	4.921"	12"	11"	12 1/2"
8"	64 13/16"	6"	5.905"	13 3/16"	12 13/16"	15"
10"	70 3/8"	6"	7.480"	16 5/8"	15 5/8"	17 1/2"

ANSI Class 600 Drain Valve with standard 60 Degree Straight Neck Discharge						
Valve Size	A Std.	B ± 1/8"	C ± .002"	D	E	F
2"	36 11/16"	6"	1.575"	6 11/16"	6 9/16"	6 1/2"
3"	45 11/16"	6"	2.362"	8 7/16"	8"	8 1/4"
4"	49"	6"	3.149"	10"	9 5/8"	10 3/4"
6"	59 3/16"	6"	4.921"	12"	12"	14"

\* Strahman piston extensions are measured from the height of the RF for an ANSI standard flange. For ANSI 600 class valves the extension is equal to the actual RF provided by Strahman. For ANSI 150 and 300 class valves the ANSI standard RF height is 1/16" while Strahman provides 3/16" height for piloting as standard. Customers can request a 1/16" RF height for RF-to-RF flange installation and the piston extension will equal the actual distance from the RF. For the Strahman standard (3/16" height) the distance measured from the RF to the tip of the piston will be 1/8" less than the description. Example: 2" ANSI 150 Drain Valve with 6" piston extension will measure 5 7/8" from a standard Strahman RF to the tip of the piston. Piston extension tolerances tighter than 1/8" available upon request.

# SERIES DV, STANDARD RANGE

## OPTIONAL ADAPTERS FOR DEAD SPACE FREE CONNECTION TO PROCESS

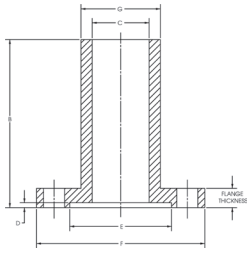

Drain Valve Adapter

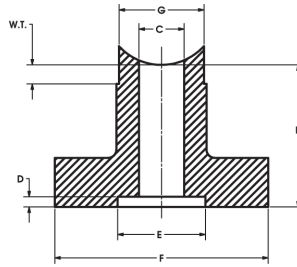

Contoured Nozzle

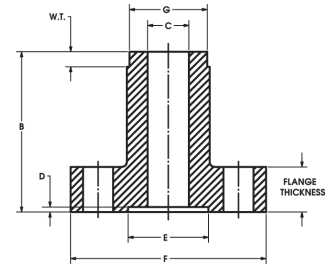

Non-Contoured Nozzle

ANSI Class 150 Adapters							
Flange Size	Flange Thickness	C	D	E	F	B Std	G
1"	1/2"	1.031"	1/8"	2.007"	4 1/4"	2"	
1 1/2"	5/8"	1.230"	11/64"	2.882"	5"	2"	
2"	11/16"	1.630"	11/64"	3.632"	6"	6"	
2 1/2"	3/4"	2.031"	11/64"	4.132"	7"	6"	
3"	3/4"	2.420"	3/16"	5.007"	7 1/2"	6"	
4"	7/8"	3.211"	3/16"	6.194"	9"	6"	
6"	15/16"	4.983"	3/16"	8.507"	11"	6"	
8"	1 1/8"	5.967"	3/16"	10.632"	13 1/2"	6"	
10"	1 1/8"	7.541"	3/16"	12.757"	16"	6"	
12"	1 3/16"	11.062"	3/16"	15.007"	19"	6"	

ANSI Class 300 Adapters							
Flange Size	Flange Thickness	C	D	E	F	B Std	G
1"	1/2"	1.031"	1/8"	2.007"	4 7/8"	2"	
1 1/2"	5/8"	1.230"	11/64"	2.882"	6 1/8"	2"	
2"	11/16"	1.630"	11/64"	3.632"	6 1/2"	5 1/2"	
2 1/2"	3/4"	2.031"	11/64"	4.132"	7 1/2"	5 1/2"	
3"	3/4"	2.420"	3/16"	5.007"	8 1/4"	5 1/2"	
4"	7/8"	3.211"	3/16"	6.194"	10"	5 1/2"	
6"	15/16"	4.983"	3/16"	8.507"	12 1/2"	5 1/2"	
8"	1 1/8"	5.967"	3/16"	10.632"	15"	6"	
10"	1 1/8"	7.541"	3/16"	12.757"	17 1/2"	6"	
12"	1 3/16"	11.062"	3/16"	15.004"	20 1/2"	6"	

ANSI Class 600 Adapters							
Flange Size	Flange Thickness	C	D	E	F	B Std	G
1"	9/16"	1.031"	15/64"	2.007"	4 7/8"	2 3/16"	
1 1/2"	5/8"	1.230"	15/64"	2.882"	6 1/8"	2 3/16"	
2"	11/16"	1.630"	15/64"	3.632"	6 1/2"	6 3/16"	
3"	3/4"	2.420"	15/64"	5.007"	8 1/4"	6 3/16"	
4"	7/8"	3.211"	15/64"	6.194"	10 3/4"	6 3/16"	
6"	15/16"	4.983"	15/64"	8.507"	14"	6 3/16"	
8"	1 1/8"	5.967"	15/64"	10.632"	16 1/2"	6 3/16"	

ANSI Class 150 Nozzles							
Flange Size	Flange Thickness	C	D	E	F	B Std	G
1"	1"	1.031"	1/8"	2.007"	4 1/4"	6"	1 7/8"
1 1/2"	1"	1.230"	11/64"	2.882"	5"	6"	2 1/8"
2"	1 1/8"	1.630"	11/64"	3.632"	6"	6"	2 1/2"
2 1/2"	1 1/8"	2.031"	11/64"	4.132"	7"	6"	2 15/16"
3"	1 3/16"	2.420"	3/16"	5.007"	7 1/2"	6"	3 3/8"
4"	1 3/16"	3.211"	3/16"	6.194"	9"	6"	4 3/8"
6"	1 1/4"	4.983"	3/16"	8.507"	11"	6"	6 1/8"
8"	1 3/8"	5.967"	3/16"	10.632"	13 1/2"	6"	7 1/4"
10"	1 7/16"	7.541"	3/16"	12.757"	16"	6"	9 1/8"
12"	1 1/2"	11.062"	3/16"	15.007"	19"	6"	13 1/4"

ANSI Class 300 Nozzles							
Flange Size	Flange Thickness	C	D	E	F	B Std	G
1"	1 1/8"	1.031"	1/8"	2.007"	4 7/8"	6"	1 15/16"
1 1/2"	1 1/8"	1.230"	11/64"	2.882"	6 1/8"	6"	2 1/8"
2"	1 1/8"	1.630"	11/64"	3.632"	6 1/2"	6"	2 1/2"
2 1/2"	1 1/4"	2.031"	11/64"	4.132"	7 1/2"	6"	2 15/16"
3"	1 3/8"	2.420"	3/16"	5.007"	8 1/4"	6"	3 3/8"
4"	1 1/2"	3.211"	3/16"	6.194"	10"	6"	4 3/8"
6"	1 11/16"	4.983"	3/16"	8.507"	12 1/2"	6"	6 1/8"
8"	1 7/8"	5.967"	3/16"	10.632"	15"	6"	7 1/4"
10"	2 1/8"	7.541"	3/16"	12.757"	17 1/2"	6"	9 1/8"
12"	2 1/4"	11.062"	3/16"	15.007"	20 1/2"	6"	13 1/4"

ANSI Class 600 Nozzles							
Flange Size	Flange Thickness	C	D	E	F	B Std	G
1"	1 1/8"	1.031"	15/64"	2.007"	4 7/8"	6 3/16"	1 15/16"
1 1/2"	1 1/8"	1.230"	15/64"	2.882"	6 1/8"	6 3/16"	2 1/8"
2"	1 1/4"	1.630"	15/64"	3.632"	6 1/2"	6 3/16"	2 1/2"
3"	1 1/2"	2.420"	15/64"	5.007"	8 1/4"	6 3/16"	3 3/8"
4"	1 3/4"	3.211"	15/64"	6.194"	10 3/4"	6 3/16"	4 3/8"
6"	2 1/8"	4.983"	15/64"	8.507"	14"	6 3/16"	6 1/8"

Nozzle Drilling: ANSI standard, bolt holes straddle centerlines.  
For nozzles with sampling valves contact Strahman direct.

Adapter Drilling: ANSI standard, bolt holes straddle centerlines.  
For adapters with sampling valves contact Strahman direct.

# SERIES VL, CUSTOM MADE RANGE

## TECHNICAL AND GENERAL INFORMATION

### FEATURES

- Extended body for flush connection to the process
- Combinations of extended body and extended piston
- Outlet angles to customer requirements
- Integral welded jackets
- Extended stuffing box with live loaded packing
- Inlet or outlet flanges in different sizes
- Connection flanges to any standard or custom design
- Custom made port sizes to optimize flow
- Wide range of metallurgy available

### DESIGN CODE AND CONSTRUCTION

- Design standard compliant with ASME B16.34
- International standards include ANSI, DIN, JIS, API etc.
- Wide range of material selections including carbon steel / stainless steel / Titanium / Hastelloy / Duplex / Monel / Tantalum / Zirconium
- Fabricated, cast, forged and bar stock designs
- Combinations of fabricated, sand and investment castings, and bar stock available

### SURFACE FINISH

- For polymer applications, Strahman recommends a surface finish of 300 (Ra 0.4) for all parts are in contact with the medium

### QUALITY ASSURANCE AND TESTING

- ISO 9001 compliant
- PED / ATEX / CE marking
- TUV / HPO / TA Luft
- Standard testing procedures
- CU TR 010
- CU TR 032

		RANGE DEFINITION										
VL Manufacturing Range												
	PN 10	PN 16	PN 20-150 lbs.	PN 25	PN 40	PN 50 300 lbs.	PN 64 400 lbs.	PN 100 600 lbs.	PN 150/160-900 lbs.	PN 250 - 1500 lbs.	PN 320	PN 420 - 2500 lbs.
3/8" - DIN10	Fig. 020											
1/2" - DIN15												
3/4" - DIN20												
1" - DIN25	Fig. 025											
1 1/4" - DIN32												
1 1/2" - DIN40												
2" - DIN50												
2 1/2" - DIN65												
3" - DIN80												
4" - DIN100												
5" - DIN125												
6" - DIN150												
8" - DIN200												
10" - DIN250												
12" - DIN300												
14" - DIN350												
16" - DIN400												
18" - DIN450												
20" - DIN500												
24" - DIN600												

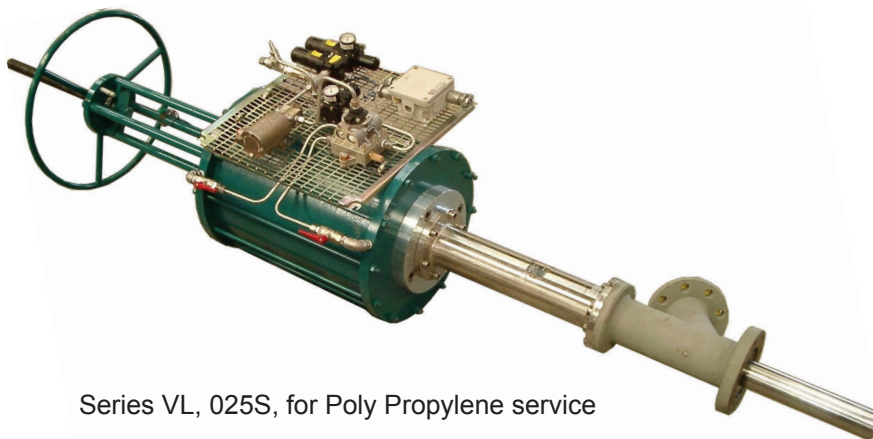

Series VL, 025S, for Poly Propylene service



Series VL, 025D with integral Welded Jacket

## SERIES VL, CUSTOM MADE RANGE

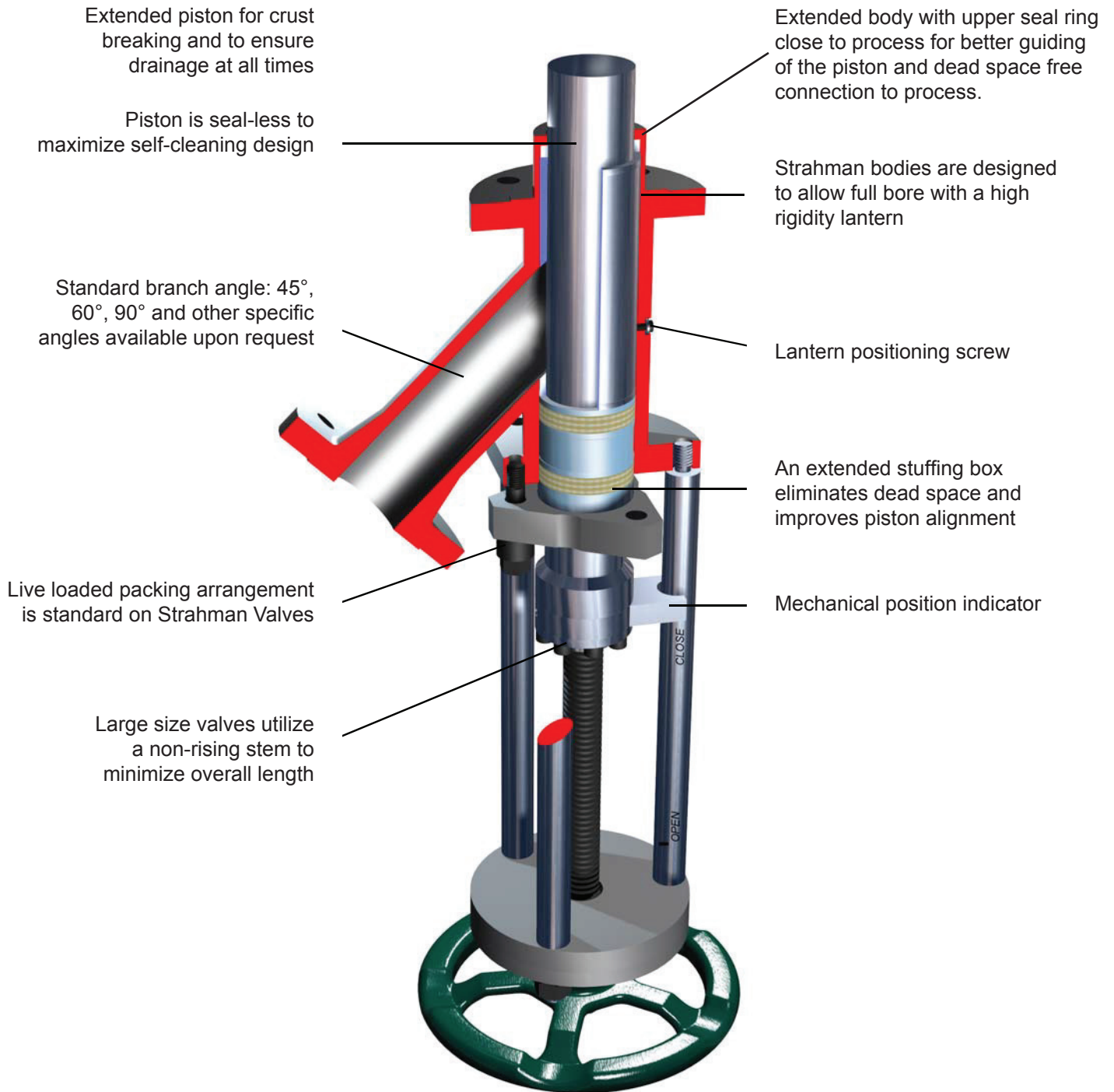

Fig. 025S

## SERIES VL, CUSTOM MADE RANGE

### BODY ARRANGEMENTS

The Strahman VL series uses the following two stem designs:

- Figure 020 for small piston sizes to approximately 25 mm (1") uses a rising stem design
- Figure 025 for piston sizes 32 mm and larger uses a non-rising stem design

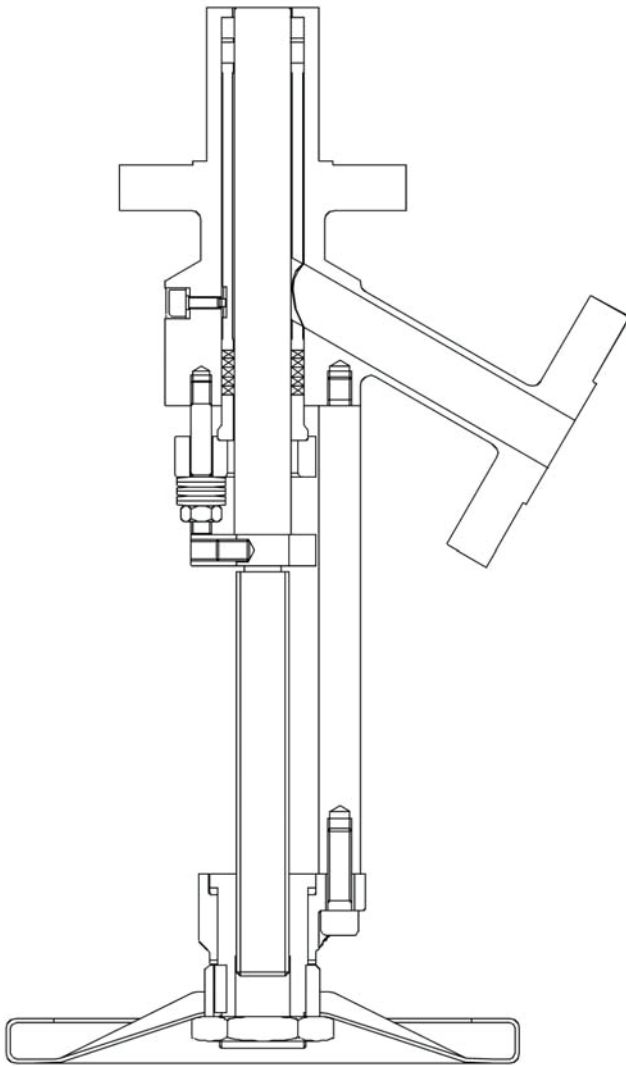

**Fig. 020**

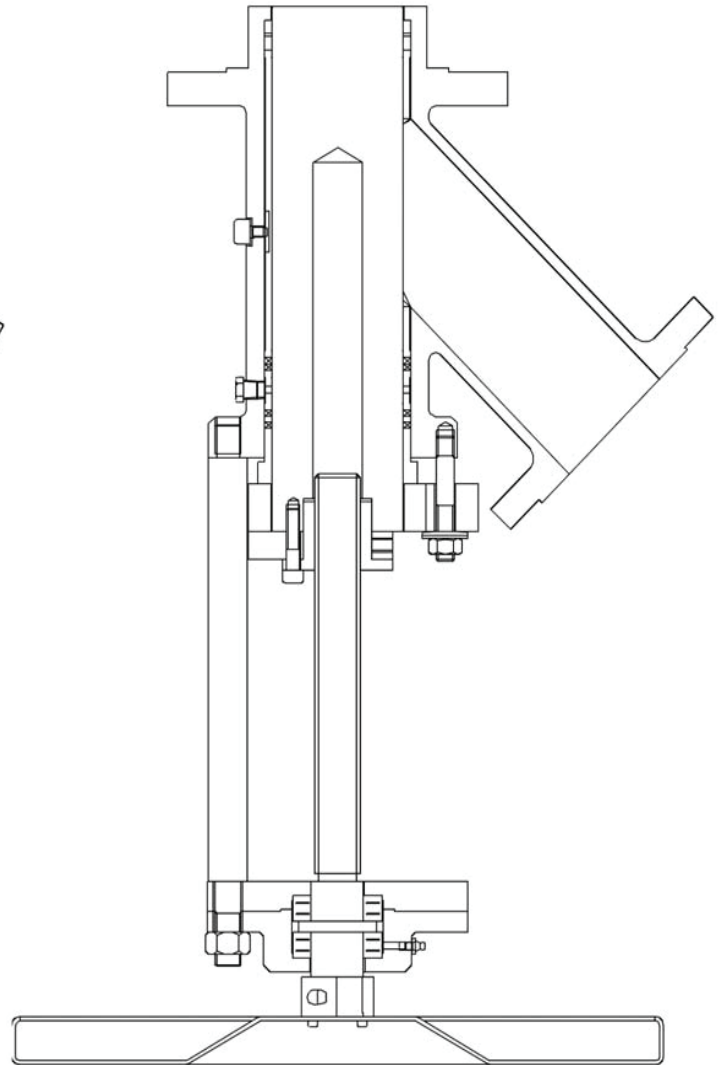

**Fig. 025**

# SERIES VL, CUSTOM MADE RANGE

## BODY ARRANGEMENTS

### SOFT SEAL

The Soft Seal is a seat-less sealing system that assures superior performance. While closing, the plunger moves through the valve bore and effectively rods any remaining product out of the valve.

- **Temperature:** Min.: -50°C / -60°F  
Max.: 200°C / 1000°F
- **Pressure:** 100 bar / 1450 PSIG

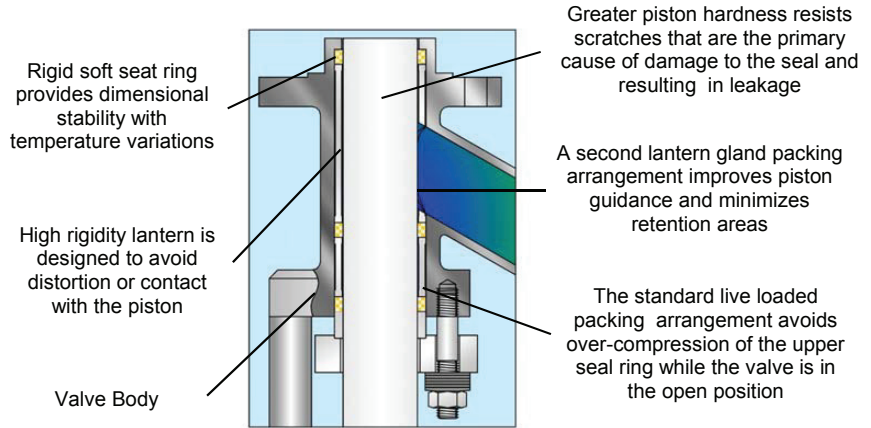

## VESSEL CONNECTIONS

To connect valves to existing vessels or reactors, there are two possibilities: a nozzle or a pad connection. In both cases, the customer must specify the following vessel connection details: **C** (inside diameter), **B** (height), **DN** (nominal size), **PN** (pressure rating) and connection **standard** (ISO, ANSI, DIN, etc.). To eliminate retention areas radius **R** can be specified for optional contouring. For new projects, Strahman can supply valves with easy-to-fit standardized pads that are ready to be installed.

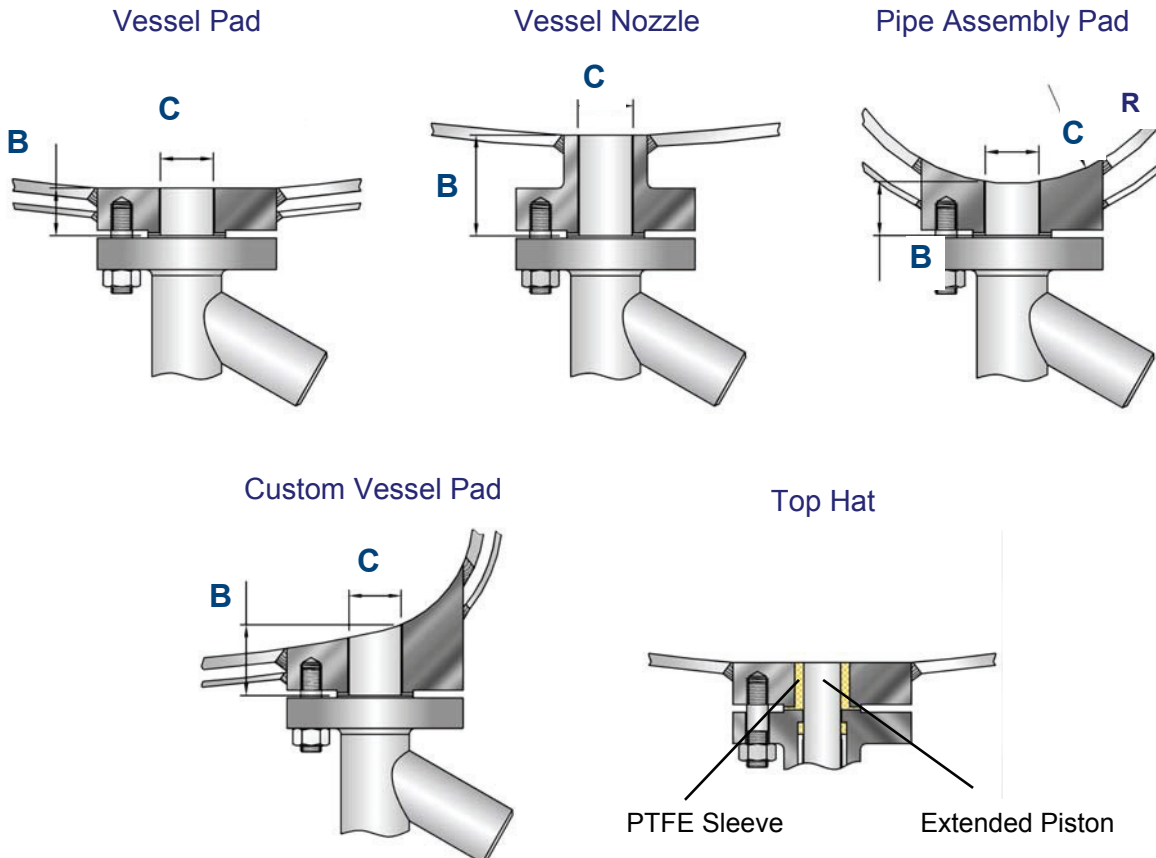

# SERIES VL, CUSTOM MADE RANGE

## PACKING DEFINITION

Typical Packing Materials:

- PTFE
- PTFE / Aramide Braid
- Carbon / Graphite Braid
- Graphite Braid
- PTFE / Aramide Braid + Graphite
- Lamellar + Expanded Graphite
- Pure Graphite

Bottom ring material is selected with a differential hardness from the piston to prevent piston damage

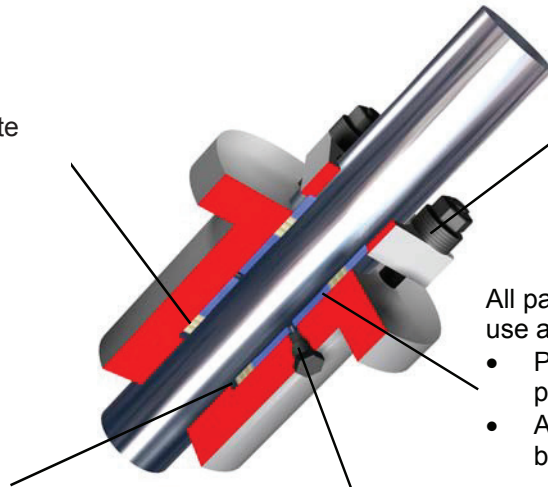

Live loaded packing arrangement minimizes valve maintenance

All packing arrangements use a lantern ring that:

- Provides better stem piston guiding
- Avoids dead space in body cavities

Optional 1/4 inch NPTF available for leak detection or inert gas injection to avoid leakage to atmosphere by creating an over pressure

## STANDARD PAD GASKET RANGE

- PTFE
- Aramide / Nitrile
- Laminated Graphite
- Laminated Graphite / 316
- Spiral Wound 316L / PTFE
- Spiral Wound 316L / Graphite
- Spiral Wound 321 / Graphite
- Spiral Wound Inconel / Graphite
- Spiral Wound Titanium / Graphite
- Perfluoroelastomer (Kalrez) O Ring
- Welded Lips
- Metallic O Ring Helicoflex Gasket Aluminum / 316
- Metallic O Ring Helicoflex Gasket Nickel / Nimonic 90
- 316L RTJ
- Nitrile O Ring
- EPDM O Ring
- Silicone O Ring
- Fluorocarbon (Viton) O Ring
- Silicone FEP Jacketed O Ring

## STANDARD BODY GASKET RANGE

- PTFE
- Aramide / Nitrile
- Carbon / Nitrile
- Laminated Graphite
- Laminated Graphite / 316
- Spiral Wound 316L / PTFE
- Spiral Wound 316L / Graphite
- Spiral Wound 321 / Graphite
- Spiral Wound Inconel / Graphite
- Spiral Wound Titanium / Graphite
- Welded Lips

## VALVE CODING SYSTEM

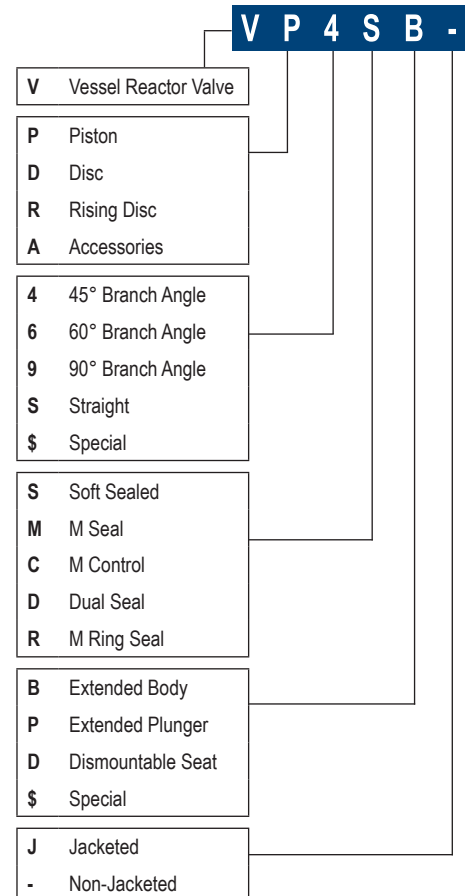

# SERIES VL, CUSTOM MADE RANGE

## LINE AND BRANCH CONNECTIONS

Soft Seal Valves can be equipped with the following end connections:



Flanges ANSI,  
DIN, JIS

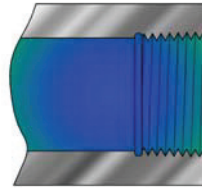

Threaded  
connections  
NPT & BSP

## ACTUATION OPTIONS



Hand Wheel



Bevel Gear

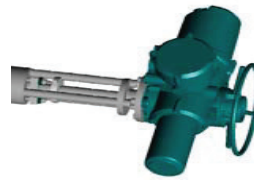

Electric Actuator

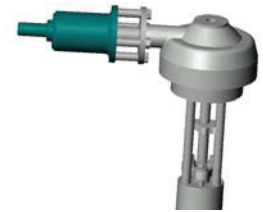

Air Motor



Double or single  
acting Air Cylinder

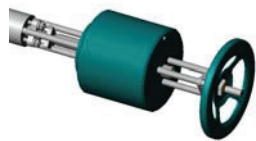

Double or single acting Air  
Cylinder with Safety Hand Wheel

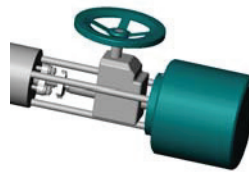

Double or single acting Air  
Cylinder with side mounted  
Safety Hand Wheel



Hydraulic  
Cylinder

## SERIES VL, CUSTOM MADE RANGE

### PISTON LOCKING DEVICE

Often times safety regulations require an additional locking device to keep a valve closed. Strahman provides three different arrangements.

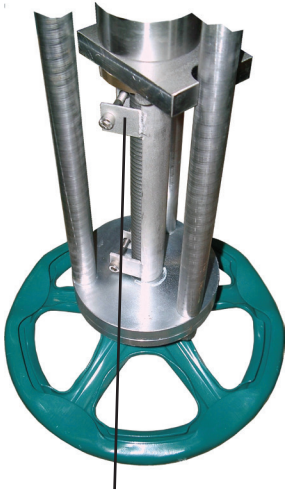

#### Arrangement A

Special half pipe blocks the stem within top works and prevents valve from stroking

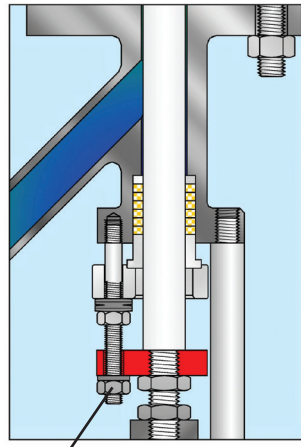

#### Arrangement B

Extended stuffing box bolts provide locking with special position indicator.

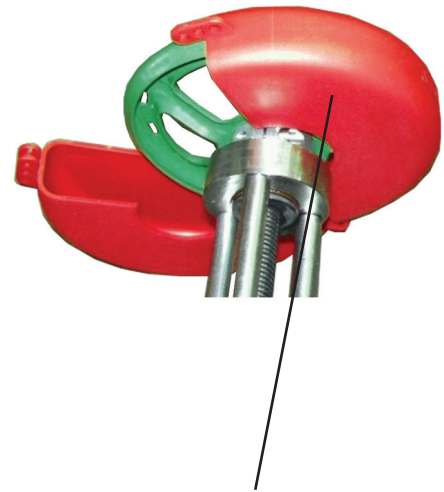

#### Arrangement C

Lockable handwheel cover.

## TEMPERATURE PROBE IN THE PISTON RTD SENSORS

A bottom valve is located right in the middle of your process. For this reason, an optional temperature probe installed in the piston will provide you with temperature information without the need of any extra nozzle or reactor modification.

For temperature sensitive processes, Strahman Valves offers piston-mounted single or dual Resistance Temperature Detectors (RTDs). The standard RTD unit has a platinum element and is available in materials to match the wetted parts of the drain valve.

Drain valves with RTDs provide several advantages over traditional thermocouples. Temperature sampling and vessel draining can be done from the same vessel nozzle. Since the drain valve is typically mounted to the bottom of the vessel, the location of the RTD at the end of the drain valve piston allows for a better temperature reading than a thermocouple mounted above the vessel agitator. RTDs provide a more stable and repeatable operation than thermocouples.

Each RTD equipped drain valve is complete with a bonnet-mounted junction box. The signal output of a RTD can be connected to a computer or data collector. An optional valve mounted temperature transmitter is also available.

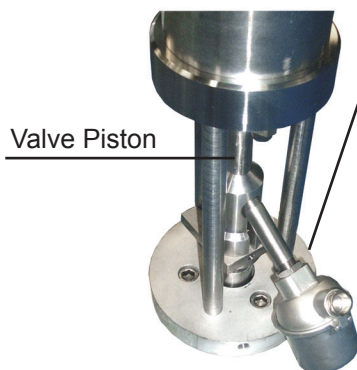

Single or Double PT100  
Temperature Probe.  
Ex-proof or standard.  
Temperature range:  
-50°C / 400°C  
-60°F / 750°F

Piston Mounted  
RTD Sensor



## SERIES VL, CUSTOM MADE RANGE

### MULTI POSITION AND BOTTOM VESSEL SAMPLING OPTIONAL CRUST BREAKING AND SAMPLING POSITION

An option exclusive to soft seal piston valves is the multiple piston position. This particular arrangement allows to move the piston while still sealing between process and outlet. This way a multi-purpose valve becomes a multi-purpose tool.

1. The ram can extend into the tank (Fig. 1). This breaks through any crust or build-up that may form on the tank bottom. The normal piston position is flush with the tank bottom.
2. The piston completely fills the valve bore so the valve cannot clog.
3. As the valve opens, the piston retracts (Fig. 2). Before the drain valve opens, the piston clears the insert ring/flange and a sample can be taken.
4. After taking the sample and closing the sampling valve, the piston continues to retract until the drain valve opens and drains the tank. (Fig. 3)
5. After draining the tank, the ram valve can be closed. The piston extends through the insert ring/flange and into the tank removing all material.

#### Bottom Vessel Sampling

A Strahman sampling valve combined with a sampling assembly can be used to sample product prior to tank draining

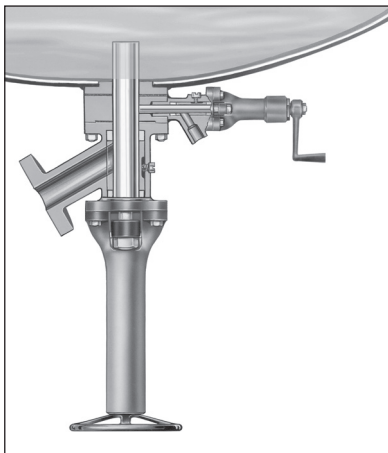
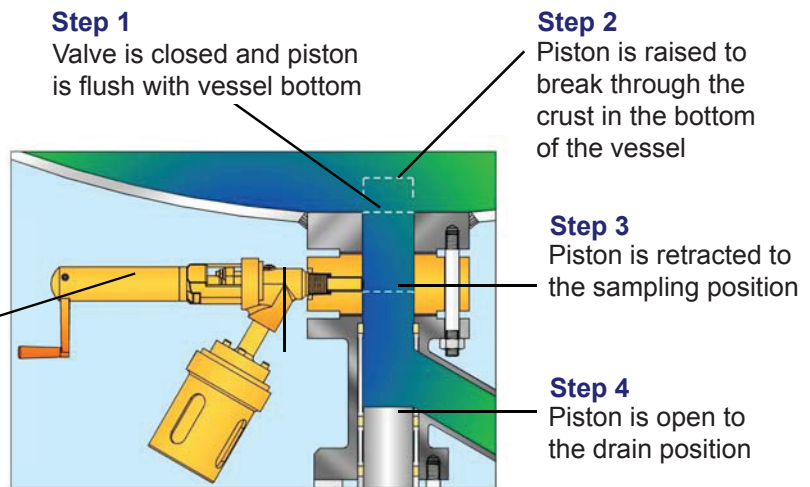

Fig. 1 - Drain Valve Fully Closed



Fig. 2 - Drain Valve Open for Sample

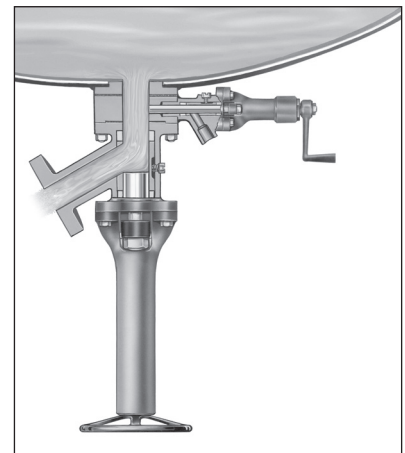

Fig. 3 - Drain Valve Fully Open

\*Shown: Strahman Insert and Sampling Valve in conjunction with the Ram-Type Drain Valve

## STRAHMAN GROUP BRANDS



### WASH DOWN EQUIPMENT

Cleaning and sanitizing equipment for applications where safety is the number one concern — built to outlast and outperform all others.



### AUTOMATED VALVES & THERMAL SHUT-OFF VALVES

Completely assembled automated valves and fire-safe thermal shut-off valves fabricated for quick and reliable problem-solving solutions for industrial applications.



### PROCESS VALVES

Engineered solutions for the transfer of fluid and flow control for highly critical applications from sampling to inline process to permanent isolation.





© STRAHMAN GROUP | PUBLISHED 11.01.25

## CONTACT US

Need more information? Give us a call today or visit our website.

 877-787-2462

 2801 Bagylos Circle  
Bethlehem, PA 18020

 [StrahmanGroup.com](http://StrahmanGroup.com)



PRECISION AND PERFORMANCE

an **fch** business