

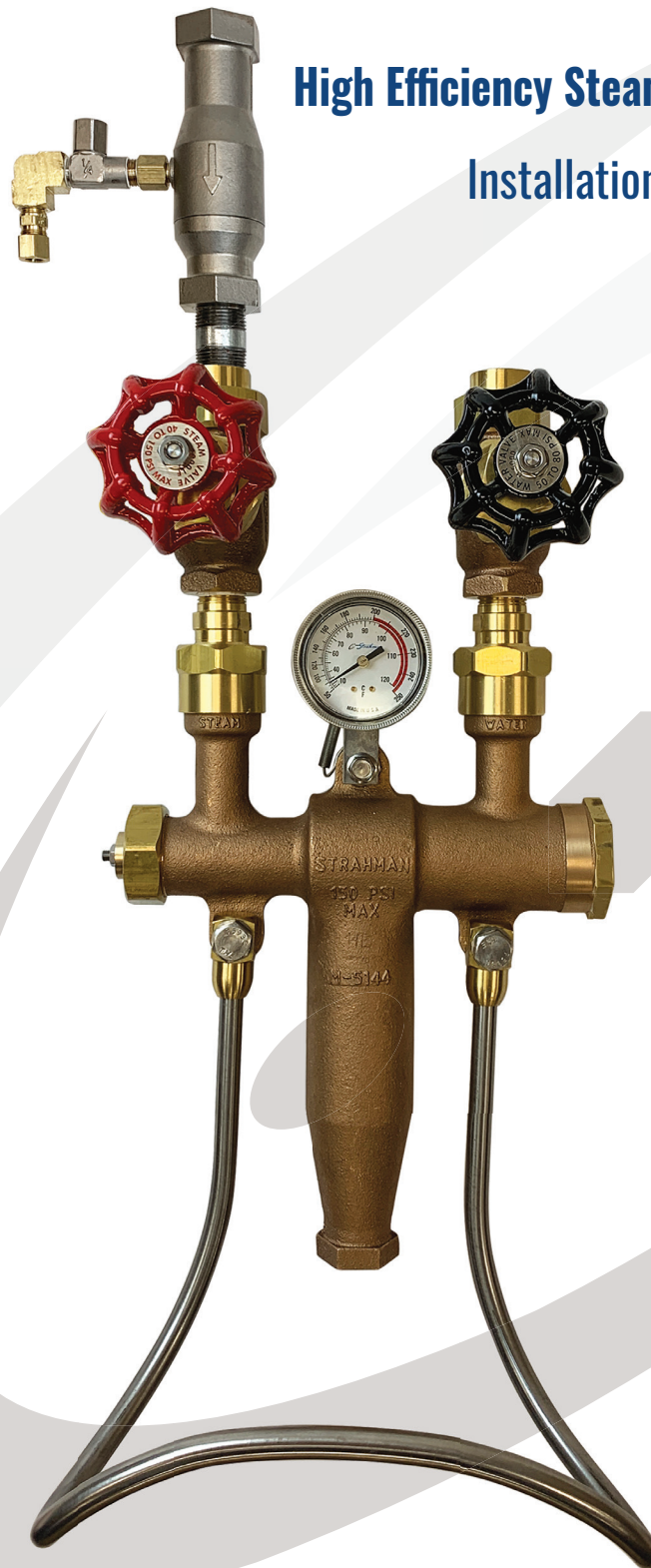

# M-5144TGHE

High Efficiency Steam & Cold Water Mixing Unit

Installation, Operation & Maintenance



 **Strahman**  
WASHDOWN EQUIPMENT

## Maintenance of Model

# M-5144TGHE

## High Efficiency Steam and Cold Water Mixing Unit

### M-5144TGHE Low Flow SERIES FOR STEAM AND COLD WATER

These units produce hot water instantly from a steady supply of steam and cold water. The M-5144TGHE High Efficiency series are equipped with a dial-type gauge that indicates the wash water's exact temperature. Users can easily regulate the temperature by turning the unit's steam and cold-water valves.

### INSTALLATION INSTRUCTIONS

Strahman Mixing Units are designed for wall mounting and are provided with necessary hexagonal spacers tapped for 3/8" bolts. They can be mounted on any type of wall by means of toggle bolts, expansion bolts or other conventional method, the only requirement being that from 5/8" to 1" of full thread be left projecting from the wall. ( See **Figure 1** )

1. Using the template provided (see attached drawing), layout and install mounting studs in wall.
2. Slide Wall plate (part 11) over stud and run on hex spacers and pulls up snug.
3. Insert short cap screw thru center mounting lug of unit and attach to corresponding spacer on wall, ALSO thru temperature gage holder on M5000 Low Flow unit.
4. Complete assembly by inserting the two long cap screws thru hose rack connector (part 4), lock washer (part 3) and thru mounting lugs on unit. Pull up all cap screws tight and the unit is ready for necessary pipe 3/4" NPT. It is important that the lock washer is placed in the proper place as this insures rigidity of installation.

**NOTE: WE RECOMMEND THIS UNIT TO BE MOUNTED 5 FEET FROM FLOOR TO CENTER LINE OF CONTROL VALVES.**

RECOMMENDED WIDTH ALLOWANCE FOR 50 FT OF HOSE 28"

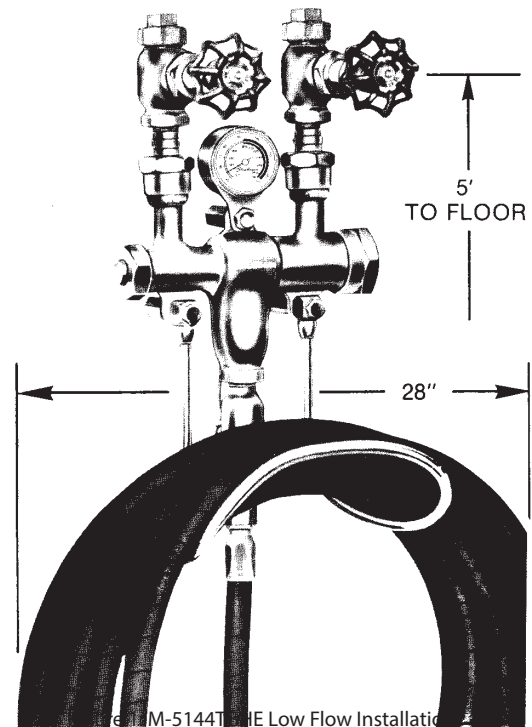
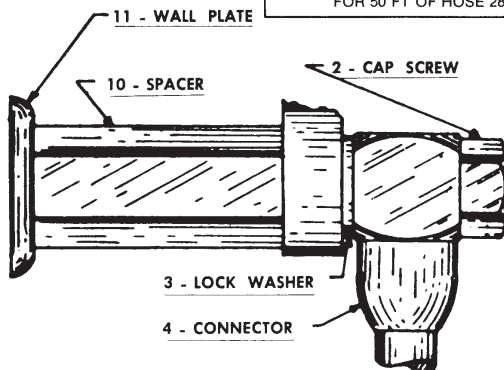

### OPERATING INSTRUCTIONS

Follow your company safety precautions during mixing unit operation.

To turn M-5144TGHE Low Flow on, follow the steps listed below:

1. Strahman recommends steam traps are installed and functioning properly.
2. Turn on the water valve, located on the right side of the unit, counter clockwise.
3. Squeeze spray nozzle until you get full water flow.
4. Slowly turn on the steam valve, located on the left side of the unit, counter clockwise until you reach the desired water temperature outlet.
5. If unit will be idled for a long period of time the unit, along with the hose, should be drained. This will help avoid a build-up of deposits. The hose should be stored on the hose rack when not in use.

See **Table 1** for easy control valves identification.

**NOTE:** If you do not get the desired water temperature outlet, turn the water valve handle clockwise until you reach the desired temperature.

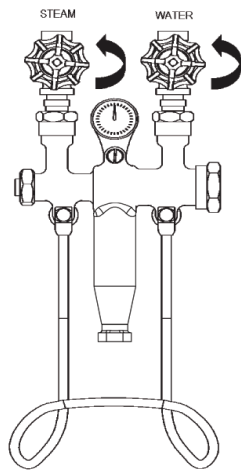

**Figure 2:** Turn control valves counter clockwise to turn M-5144TGHE Low Flow on.

To turn M-5144TGHE Low Flow off, follow the steps listed below:

1. Shut off the steam valve completely.
2. Shut off the water valve completely.
3. Relieve any pressure in the unit by opening the spray nozzle.

**CAUTION:** If internal pressure is not relieved when shutting the unit off, steam will come out at the spray nozzle when first open. Shut M-5144TGHE Low Flow down when unit is not being used.

If unit is not shut down the steam will boil the water in the unit and cause steam to come from nozzle when first turned on.

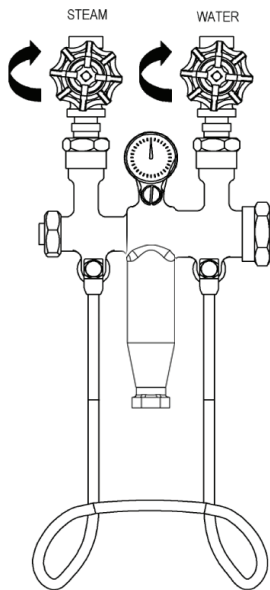

**Figure 3:** Turn Off control valves clockwise to turn M-5144TGHE Low Flow off.

	COLOR	
	STEAM	WATER
M-5144TGHE	RED	BLACK

**Table 1:** Control Valves Color Identification

For more information, please contact your Strahman representative.

## MAINTENANCE INSTRUCTIONS

The Strahman Instant Hot Water Maker must be maintained properly in order to get the best results. The steam passing through the unit is controlled by a steam poppet (5), which should be replaced as soon as it becomes worn, This can easily be done by following the steps below. (See page 3 & Table 2)

1. First close the control valves, and allow the unit to cool.
2. Then remove the hex nut (21) on the left side of the unit.
3. Remove the poppet (5) guide assembly (parts 20, 26, 27 & 28) the assembly should easily slide out of the unit with little effort.
4. The poppet can now be removed using the special tool furnished in the M-5144TGHE Low Flow Service Kit. (See Page 3)
5. The new poppet can now be installed using the same tool, guide assembly, and guide nut (torque guide nut to 75 Ft-Lbs – 100 Ft-Lbs Max.)
6. The unit is now ready for use.

In extremely sever cases it may be necessary to replace the poppet seat, (7). This can be done with the poppet and guide assembly removed as in the previous steps.

1. Use the Poppet seat tool
2. Insert tool and turn counter clock-wise to loosen and remove the poppet seat.
3. Reinstall the poppet seat by turning the seat tool in clock-wise until snug.

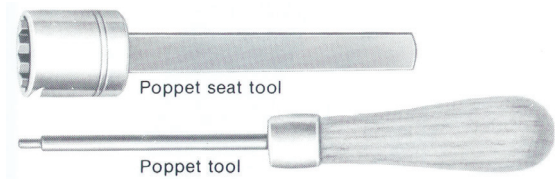

**NOTE:** If leakage occurs at the poppet guide assembly, immediately turn off both control valves. Relieve any pressure in the unit by opening the spray nozzle. Allow the unit to cool down before removing the poppet guide nut. Remove poppet guide nut and poppet guide assembly (See Figure 4). Clean the area where the poppet guide seats in the M-5144TGHE body. Clean the seating area of the poppet guide and apply pipe dope. Reinstall the poppet guide assembly and poppet guide nut. Torque the poppet guide nut to 75 ft-lbs. Do not exceed 100 ft-lbs.

Follow this procedure whenever the poppet guide assembly is removed.

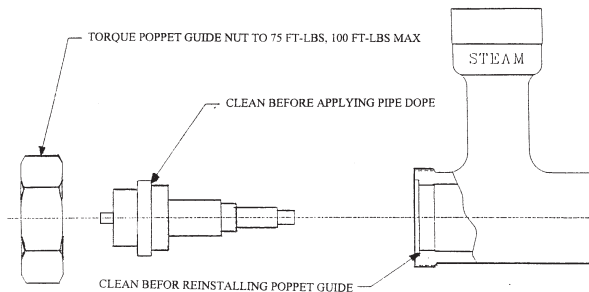

**Figure 4:** M-5144TGHE Low Flow poppet guide seat assembly.

## M-5144TGHE LOW FLOW POPPET STOP ADJUSTMENT

1. After initial installation and wearing proper protective equipment open both inlet valves fully. Check for leaks and correct if necessary.
2. Loosen the lock nut (32) on the poppet stop assembly and using a 1/8" Allen wrench turn the poppet stop (25) clockwise until it stops, do not force. Then turn the stop #25 counter clockwise to open three-quarters of a turn and snug the lock nut temporarily.
3. Operate the spray nozzle fully open for at least a minute to purge any air or condensate.
4. Loosen the lock nut (32) and using the 1/8" Allen wrench turn either clock wise to lower the temperature or counterclockwise to raise the temperature. Tighten the lock nut (32), turning clockwise when the desired temperature has been reached. Caution do not force the stop open as this can cut the o-ring (33).

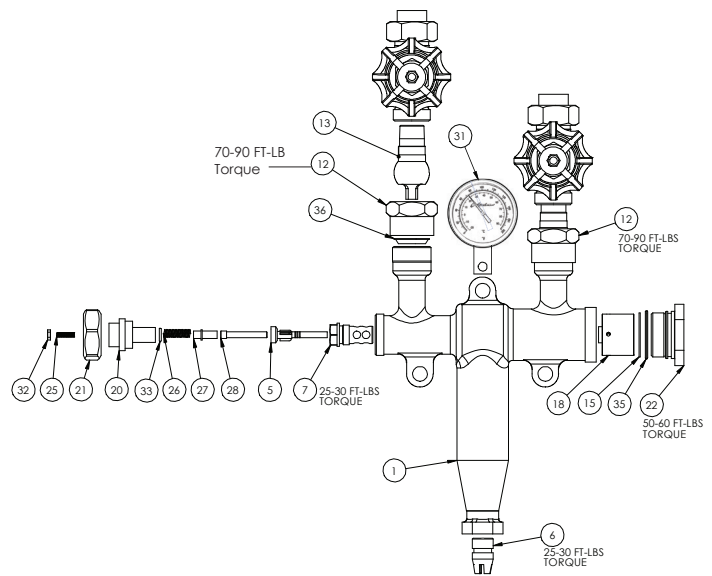

PARTS		
PART NO.	PART	M-5144TGHE Low Flow MATERIAL
1	BODY	BRONZE
2	HOSE RACK CAP SCREW (not shown)	STAINLESS STEEL
3	HOSE RACK LOCK WASHER (not shown)	STAINLESS STEEL
4	HOSE RACK CONNECTOR (not shown)	BRASS
5	STEAM POPPET	STAINLESS STEEL
6	STEAM JET	STAINLESS STEEL
7	POPPET SEAT	BRONZE
8	HOSE RACK (not shown)	STAINLESS STEEL
10	SPACER (not shown)	STAINLESS STEEL
11	WALL PLATE (not shown)	BRASS
12	BALL CHECK UNION NUT	BRASS
13†	BALL CHECK VALVES (includes part 36)	BRASS/STAINLESS STEEL ALUMINUM SILICONE BRONZE
15	RETAINING RING	STAINLESS STEEL
18	WATER CHAMBER	STAINLESS STEEL
20	POPPET GUIDE	BRASS
21	POPPET GUIDE NUT	BRASS
22	BODY NUT	BRONZE
25	POPPET STOP	STAINLESS STEEL
26	GUIDE HOUSING	STAINLESS STEEL
27	GUIDE EXTENSION	STAINLESS STEEL
28	PUSHER	STAINLESS STEEL
31**	TEMP GAUGE	STAINLESS STEEL
32	JAM NUT	STAINLESS STEEL
33	O-RING POPPET STOP	EPDM
35	LOW FLOW O-RING	EPDM
36	BALL CHECK GASKET	COPPER

†Sold as a complete unit.

\*\*Temperature gauge: 40-120°C/100-250°F.

# Strahman Water-Saver Spray Nozzle

Also available in stainless steel.



## Instruction for Servicing

**(Caution: Not for use on steam hose)**

The entire working parts of the Strahman Water-Saver Spray Nozzle are contained in a single cartridge (F, J, M, S). This cartridge can be removed by:

1. Remove rubber cover (20) by slipping the rubber off the back of nozzle and pulling over front.
2. Remove lever arm screw and nut (24) and remove lever arm (6)
3. Unscrew lock screw (30) and extract the cartridge from back end of nozzle with cage (18).
4. To insert new cartridge, reverse above procedure.
5. Be sure when replacing cage (18) to place cut-away part of cage facing downward, so lever arm (6) can be inserted.
6. Be sure lever arm is placed ahead of stem guide (31) on cartridge unit.
7. To replace cover wipe body with detergent, insert nozzle end first then handle into cover. Use a round ended tool approx. 3/8" in diameter to stretch cover over back. Sharp tools can cut cover.

## Parts List

- F Renewable Cartridge Unit — Model F-90 Series
- SF Renewable Cartridge Unit — Model F-90 SS Series
- J Renewable Cartridge Unit — Model S-80 Series
- SJ Renewable Cartridge Unit — Model S-80 SS Series
- M-70 Renewable Cartridge Unit — Model M Series (shown)
- S-70 Renewable Cartridge Unit — Model S Series
- 6. Lever Arm
- 8-S. Stainless Steel Seat
- 18. Cage
- 20B. Renewable Rubber Cover (Black)
- 20R. Renewable Rubber Cover (Red)
- 20W. Renewable Rubber Cover (White)
- 21. Hose Adapter (1/2", 5/8", 3/4") (3/4" Garden Hose Thread)
- 21S. Swivel Hose Adapter (1/2", 5/8", 3/4") (3/4" Garden Hose Thread)
- 22. Lever Arm Bushing
- 24. Lever Arm Screw and Nut
- 28. Lock Rings
- 29. Body
- 30. Lock Screw
- 31. Stem Guide
- 32. Body Sealing O-ring

# The Strahman Soft Seal Piston Valve

V-14-U 3/4" Globe (Shown)

V-18 3/4" Angle, V-14S (Screwed End)

V-65-SU 3/4" Globe Stainless Steel

V-18-S 3/4" Angle Stainless Steel

Note: Globe (Union Connection) Valve Shown.

Angle Valve Not Shown.

PARTS	
PART NO.	PART
1	BODY SCREWED ENDS
1	BODY SCREWED ENDS SS
1	BODY UNION TYPE
3	VALVE RING
4	PISTON
5	SPLITNUT
6	STEM (includes part 7)
7	STEM STOP (set of 6)
8	LANTERN
9	SPRING
10	BONNET Bronze
10	BONNET SS 303
11	BONNET NUT
11	BONNET NUT SS 303
12	RETAINING RING (set of 6)
13	PACKING RING
14	PACKING GLAND
15	PACKING NUT
15	PACKING NUT SS 303
16	BLACK HANDWHEEL
16	RED HANDWHEEL
17	HANDWHEEL NUT (set of 6)
20	UNION GASKET (set of 6)
20	SPIRAL WOUND GASKET Graphite
21	UNION TAIL PIECE
22	UNION INLET NUT
23	ANGLE RECESSED GASKET

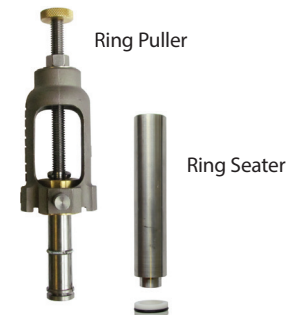
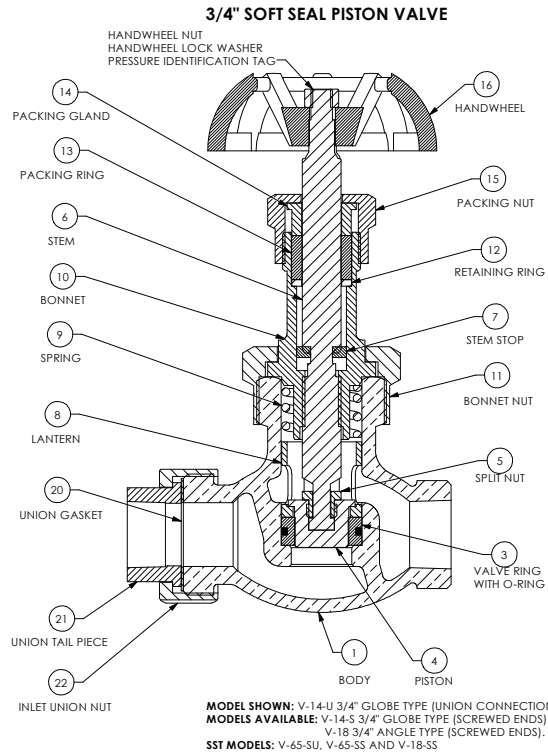

Note: When installing new spring, splitnut no. 5 and piston no. 4 must be disassembled from stem no. 6. Install new spring over stem against bonnet. Reassemble splitnut and piston. Hold spring against bonnet.

## Instructions for Use of Tools with Soft Seal Piston Valve

### Extracting Valve Ring

- First** Remove bonnet and stem assembly by opening valve to wide open position and removing bonnet nut and working assembly free of body.
- Second** Insert pulling tool into ring pocket making sure that puller housing is located evenly on neck of valve body. Slotted cap 'A' should rest on lantern as shown in Fig. 1. Rotate until pin 'B' can be pressed into slot and hold while knurled nut 'C' counter clockwise until refusal.
- Third** With an adjustable wrench, turn hex nut 'D' in a clockwise direction until internal parts are fully extracted, as shown in Fig. 2.
- Fourth** Spin hex nut all the way back on so that withdrawn parts can be fully extended from puller housing, then turn knurled nut 'C' clockwise which will release parts from puller.

5

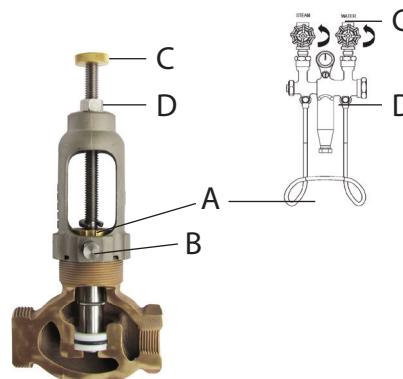

Fig. 1

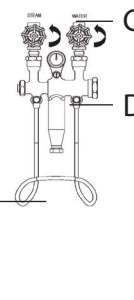

Fig. 2

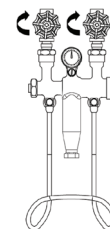

Fig. 3

### To Insert New Valve Ring

- First** Place valve ring, including O-ring, on seating tool as shown in Fig. 3 and drive into valve body as far as it will go keeping sealer tool as straight as possible.
- Second** Drop lantern into body with large I.D. and wider band facing up making sure lantern sits evenly on ring.
- Third** Before installing bonnet assembly into body, fully retract stem making sure spring is located between back of piston and bonnet. Install into body. Tighten down bonnet nut until refusal.

**Precautions: Make sure ring pocket is free of scale, rust or other obstruction before replacing valve ring. Make sure parts are replaced in same order as removed.**

**Base ring no longer necessary (older valves only).**

Maintenance of Model

# M-5144TG HETG/5700TG

## Steam and Cold Water Mixing Unit

### TEMPLATE FOR MOUNTING M-5144TGHE STRAHMAN INSTANT HOT WATER MAKER

THREE 3/8" STUDS N.C. - STUDS MUST STICK OUT 5/8" TO 1" FROM WALL.

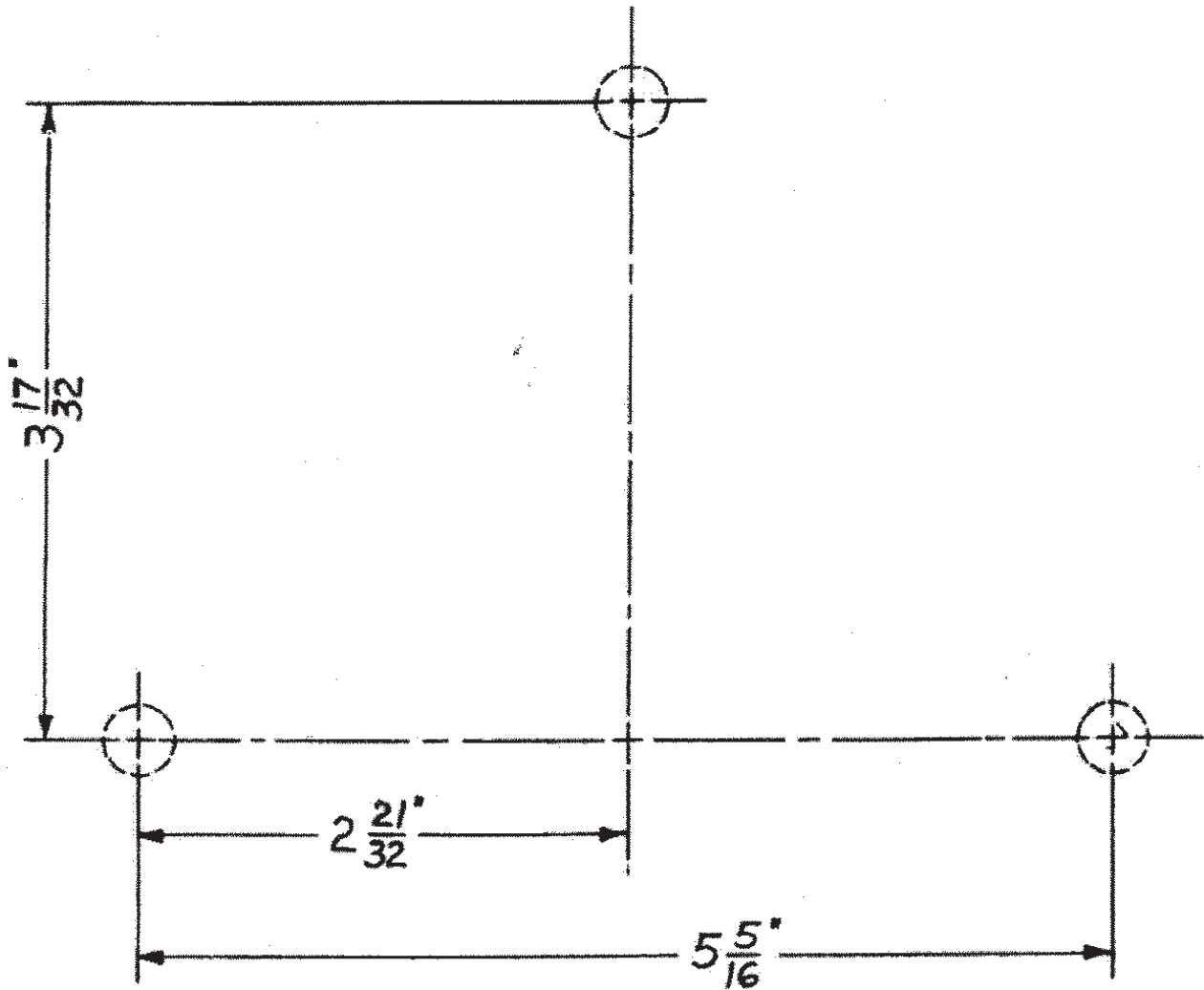

NOTE: THESE UNITS HAVE SPACERS (10) AND LOCK WASHERS (3) ATTACHED. SPACER MUST BE DETACHED FOR MOUNTING. SPECIAL CARE IS ADVISED FOR THE CENTER SPACER WHICH HOLDS THE TEMPERATURE GAUGE IN PLACE.

The Strahman Family of Products Include:



## Wash Down Equipment

Cleaning and sanitizing equipment for applications where safety is the number one concern — built to outlast and outperform all others.

## Automated Valves & thermal shut-off valves

Completely assembled automated valves and fire-safe thermal shut-off valves fabricated for quick and reliable problem-solving solutions for industrial applications.

## Process valves

Engineered solutions for the transfer of fluid and flow control for highly critical applications from sampling to inline process to permanent isolation.





© STRAHMAN GROUP | PUBLISHED 11.01.25

## CONTACT US

Need more information? Give us a call today or visit our website.

 877-787-2462

 2801 Bagylos Circle  
Bethlehem, PA 18020

 [StrahmanGroup.com](http://StrahmanGroup.com)



PRECISION AND PERFORMANCE

an fch business